

STRATA PLAN OF LOT A BLOCK 7 DISTRICT LOT 325 GROUP 1 NEW WESTMINSTER DISTRICT PLAN BCP50382 EXCEPT AIR SPACE PLAN EPP42046

STRATA PLAN EPS2354

BCGS 92G.025



THE INTENDED PLOT SIZE OF THIS PLAN IS 560mm IN WIDTH BY 432mm IN HEIGHT (C SIZE) WHEN PLOTTED AT A SCALE OF 1:400.

INTEGRATED SURVEY AREA NO. 31, CITY OF VANCOUVER, NAD83 (CSRS) 4.0.0.BC.1.GVRD

GRID BEARINGS ARE DERIVED FROM OBSERVATIONS BETWEEN GEODETIC CONTROL MONUMENTS V-3768 AND V-3882.

THIS PLAN SHOWS HORIZONTAL GROUND-LEVEL DISTANCES UNLESS OTHERWISE SPECIFIED. TO COMPUTE GRID DISTANCES, MULTIPLY GROUND-LEVEL DISTANCES BY THE AVERAGE COMBINED FACTOR OF 0.9998604 WHICH HAS BEEN DERIVED FROM CONTROL MONUMENTS V-3768 AND V-3882.

INDICATES TYPICAL COORDINATE POINT AND CONSIDERED NUMBERING WITH AIR SPACE PLAN EPP42046.

FOR THREE-DIMENSIONAL COORDINATE POINT VALUES FOR TYPICAL POINTS INDICATED THUS: (B)

ALL ANGLES OF BUILDING WALLS AND BALCONIES ARE COMPONENTS OF 45° UNLESS NOTED OTHERWISE.

PATIOS, BALCONIES, DECKS AND ROOF TERRACES ARE LIMITED COMMON PROPERTY FOR THE USE OF THE STRATA LOT INDICATED. (EX. P-1, B-25, D-16, RT-28)

ALL IMPROVEMENTS SHOWN ARE SOME FORM OF COMMON PROPERTY UNLESS INDICATED AS PART OF STRATA LOT.

STRATA LOT BOUNDARIES ARE MEASURED TO THE COMMON PROPERTY SIDE OF WALLS AND/OR THE EXTERNAL GLASS LINE BETWEEN STRATA LOTS AND COMMON PROPERTY AND TO THE CENTRELINE OF WALLS BETWEEN ADJACENT STRATA LOTS SUBJECT TO THE FOLLOWING NOTES:

WHERE THERE ARE STRUCTURAL WALLS THAT COMPRISE SOME PORTION OF THE BOUNDARIES OF STRATA LOTS AND WHERE THOSE BOUNDARIES ARE BETWEEN STRATA LOTS AND COMMON PROPERTY, FOR THE PURPOSES OF DETERMINING THE LOCATIONS OF THOSE STRATA LOT BOUNDARIES WITHIN THOSE PARTICULAR WALLS, ONLY A PORTION OF THE WIDTH OF THE SPECIFIC WALLS, EQUIVALENT TO THE WIDTH OF THE ADJACENT EXTERNAL FRAMED WALL, ARE INCLUDED IN THE STRATA LOT AREAS.

WHERE WALLS DELINEATE PARTS OF THE BOUNDARIES BETWEEN TWO ADJACENT STRATA LOTS, THE CENTRE-LINES OF THE WALLS SHALL DEFINE THE COMMON BOUNDARIES BETWEEN THE STRATA LOTS.

LEGEND

- INDICATES CONTROL MONUMENT FOUND
- INDICATES STANDARD IRON POST FOUND
- C.P. INDICATES COMMON PROPERTY
- SL INDICATES STRATA LOT
- PT INDICATES PART
- m² INDICATES SQUARE METRES
- P INDICATES PATIO
- B INDICATES BALCONY
- D INDICATES DECK
- RT INDICATES ROOF TERRACE
- M INDICATES MECHANICAL - C.P.
- ELEC INDICATES ELECTRICAL ROOM/CLOSET - C.P.
- INDICATES PLANIMETRIC EXTENTS OF AIR SPACE PLAN EPP42046 SHADED FOR THE PURPOSE OF CLARITY

CIVIC ADDRESS:

8488 CORNISH STREET
VANCOUVER, B.C.

NAME OF DEVELOPMENT:

GRANVILLE AT 70th
LOT A BUILDING 4
PHASE 3
8488 CORNISH STREET

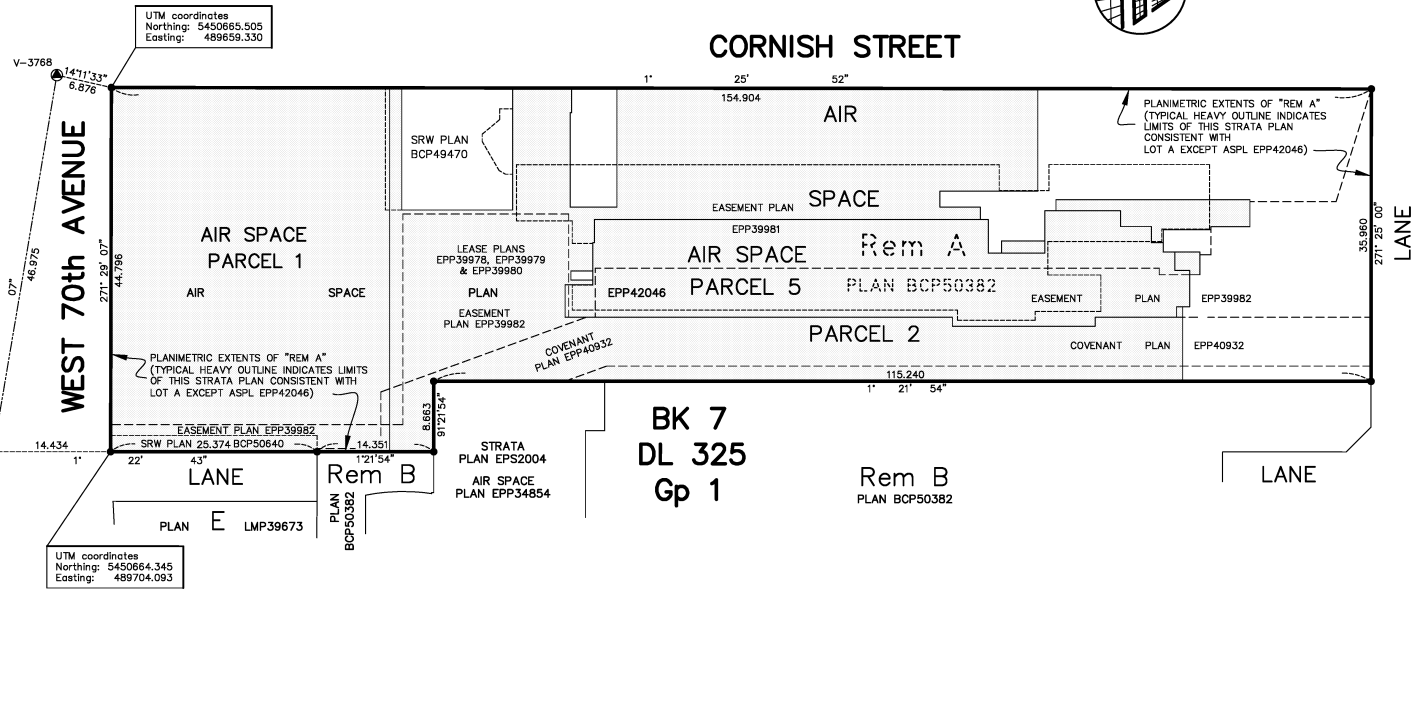
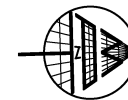

MATSON PECK & TOPLISS
SURVEYORS & ENGINEERS
#320 - 11120 HORSESHOE WAY
RICHMOND, B.C. V7A 5H7
PH: 604.270.9331 FAX: 604.270.4137
CADFILE:16400-REM A-STRATA.DWG

V-16400-REM-A-STRATA

THE BUILDING IN THIS STRATA PLAN HAS NOT BEEN PREVIOUSLY OCCUPIED.

THE BUILDING SHOWN HEREON IS WITHIN THE EXTERNAL BOUNDARIES OF THE LAND THAT IS THE SUBJECT OF THE STRATA PLAN.

THIS PLAN LIES WITHIN THE CITY OF VANCOUVER.

THIS PLAN LIES WITHIN THE GREATER VANCOUVER REGIONAL DISTRICT.

THE FIELD SURVEY REPRESENTED BY THIS PLAN WAS COMPLETED ON THE 9th DAY OF SEPTEMBER, 2014 HANS J. TROELSEN, BCLS 551

PARKADE – BUILDING FOUNDATION OUTLINE

SHEET 2 OF 29 SHEETS

STRATA PLAN EPS2354



THE INTENDED PLOT SIZE OF THIS PLAN IS 560mm IN WIDTH BY 432mm IN HEIGHT (C SIZE) WHEN PLOTTED AT A SCALE OF 1:300.

INDICATES EXTERIOR FACE OF PARKADE FOUNDATION WALL

THIS SHEET SHOWS DIMENSIONS TO EXTERIOR FOUNDATION WALLS.

FOR THE PURPOSE OF CLARITY, BUILDING OFFSETS TO PROPERTY LINES ARE PLOTTED NOT TO SCALE.

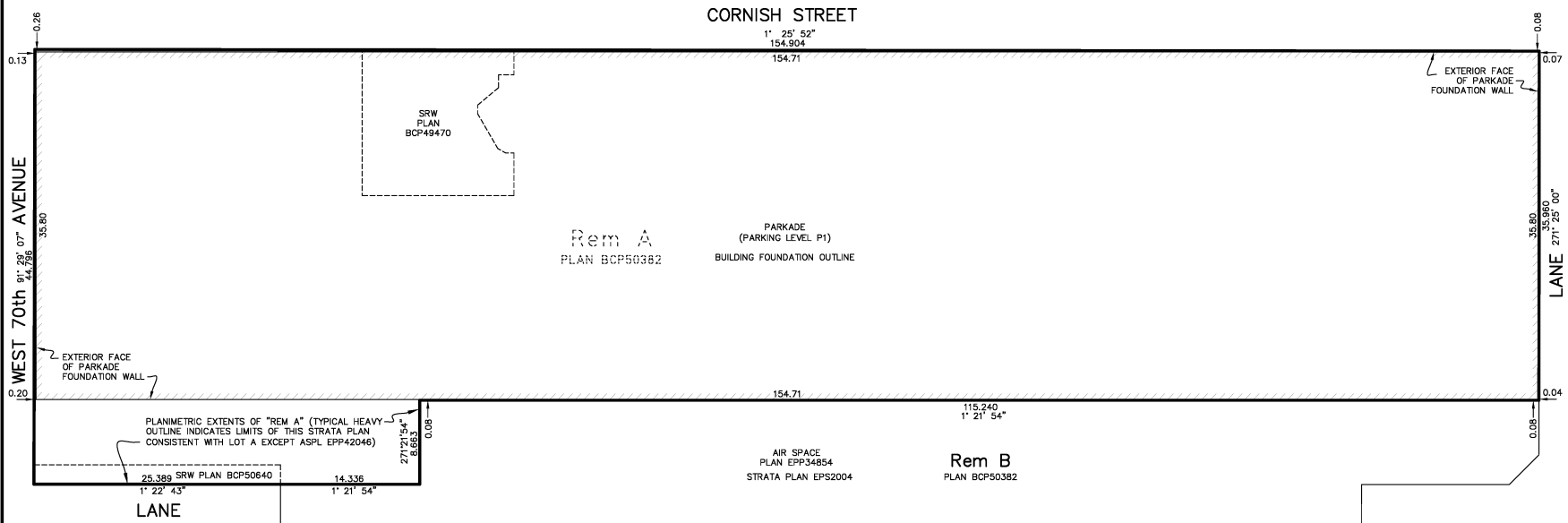
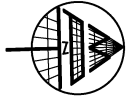

MATSON PECK & TOPLISS
SURVEYORS & ENGINEERS
#320 - 11120 HORSESHOE WAY
RICHMOND, B.C. V7A 5H7
PH: 604-270-9331 FAX: 604-270-4137
CADFILE:16400-REM A-STRATA.DWG

HANS J. TROELSEN, BCLS 551
9th DAY OF SEPTEMBER, 2014

STRATA PLAN EPS2354

ISOMETRIC

10 5 0 10 20

THE INTENDED PLOT SIZE OF THIS PLAN IS 560mm IN WIDTH BY 432mm IN HEIGHT (C SIZE) WHEN PLOTTED AT A SCALE OF 1:500.

PLAN SHOWS RELATIVE SPATIAL LOCATION OF PARTS OF AIR SPACE PLAN EPP42046 WITHIN LOT A PLAN BCP50382.

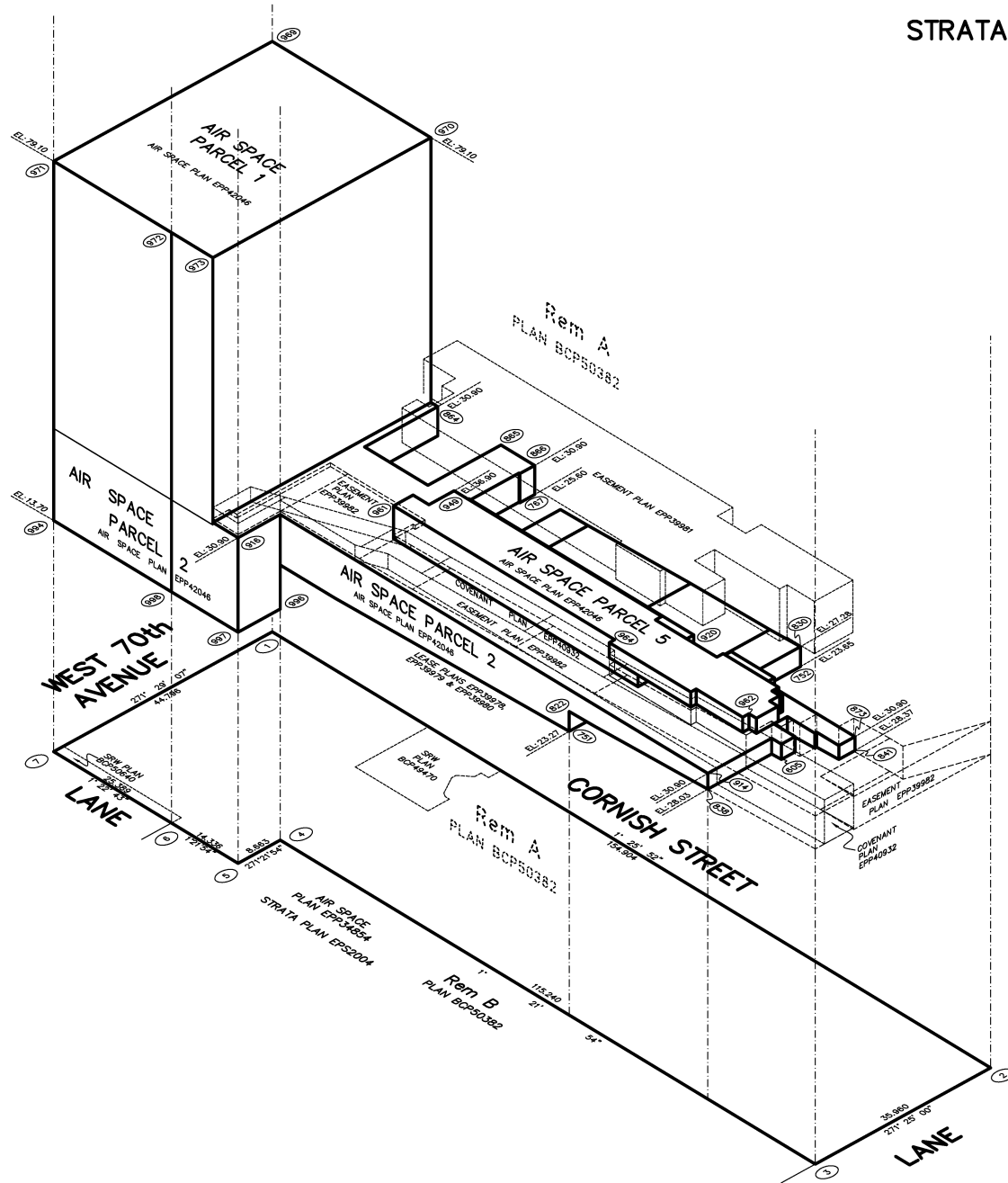

MATSON PECK & TOPLISS
 SURVEYORS & ENGINEERS
 #320 - 11120 HORSESHOE WAY
 RICHMOND, B.C. V7A 5H7
 PH: 604.270.9331 FAX: 604.270.4137
 CADFILE:16400-REM A-STRATA.DWG

HANS J. TROELSEN, BCLS 551
 9th DAY OF SEPTEMBER, 2014

PARKING LEVEL P3

SHEET 4 OF 29 SHEETS

STRATA PLAN EPS2354



THE INTENDED PLOT SIZE OF THIS PLAN IS 560mm IN WIDTH BY 432mm IN HEIGHT (C SIZE) WHEN PLOTTED AT A SCALE OF 1:300.

THIS SHEET SHOWS WALL DIMENSIONS ACCORDING TO PARAMETERS AS NOTED ON SHEET 1 OF THIS STRATA PLAN.

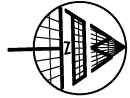

CORNISH STREET

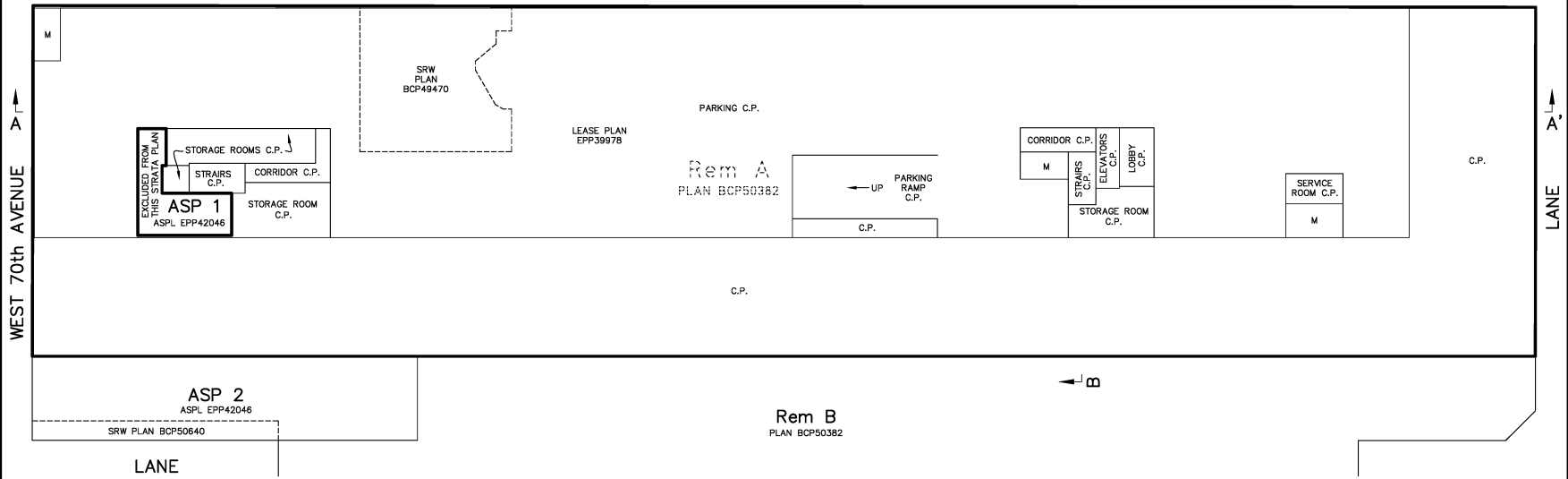

MATSON PECK & TOPLISS
 SURVEYORS & ENGINEERS
 #320 - 11120 HORSESHOE WAY
 RICHMOND, B.C. V7A 5H7
 PH: 604-270-9331 FAX: 604-270-4137
 CADFILE:16400-REM A-STRATA.DWG

HANS J. TROELSEN, BCLS 551
 9th DAY OF SEPTEMBER, 2014

PARKING LEVEL P2

SHEET 5 OF 29 SHEETS

STRATA PLAN EPS2354



THE INTENDED PLOT SIZE OF THIS PLAN IS
560mm IN WIDTH BY 432mm IN HEIGHT (C SIZE)
WHEN PLOTTED AT A SCALE OF 1:300.

THIS SHEET SHOWS WALL DIMENSIONS ACCORDING TO
PARAMETERS AS NOTED ON SHEET 1 OF THIS STRATA PLAN.

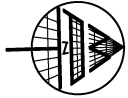

CORNISH STREET

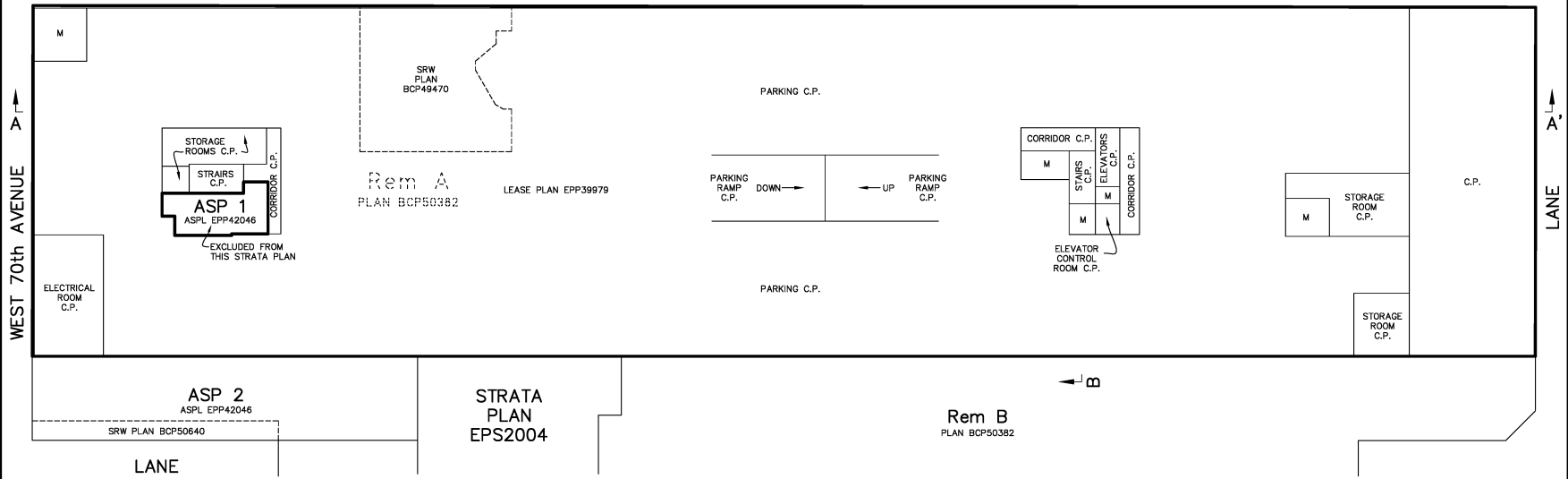

MATSON PECK & TOPLISS
SURVEYORS & ENGINEERS
#320 - 11120 HORSESHOE WAY
RICHMOND, B.C. V7A 5H7
PH: 604-270-9331 FAX: 604-270-4137
CADFILE:16400-REM A-STRATA.DWG

HANS J. TROELSEN, BCLS 551
9th DAY OF SEPTEMBER, 2014

PARKING LEVEL P1

STRATA PLAN EPS2354

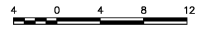

THE INTENDED PLOT SIZE OF THIS PLAN IS 560mm IN WIDTH BY 432mm IN HEIGHT (C SIZE) WHEN PLOTTED AT A SCALE OF 1:300.
 THIS SHEET SHOWS WALL DIMENSIONS ACCORDING TO PARAMETERS AS NOTED ON SHEET 1 OF THIS STRATA PLAN.

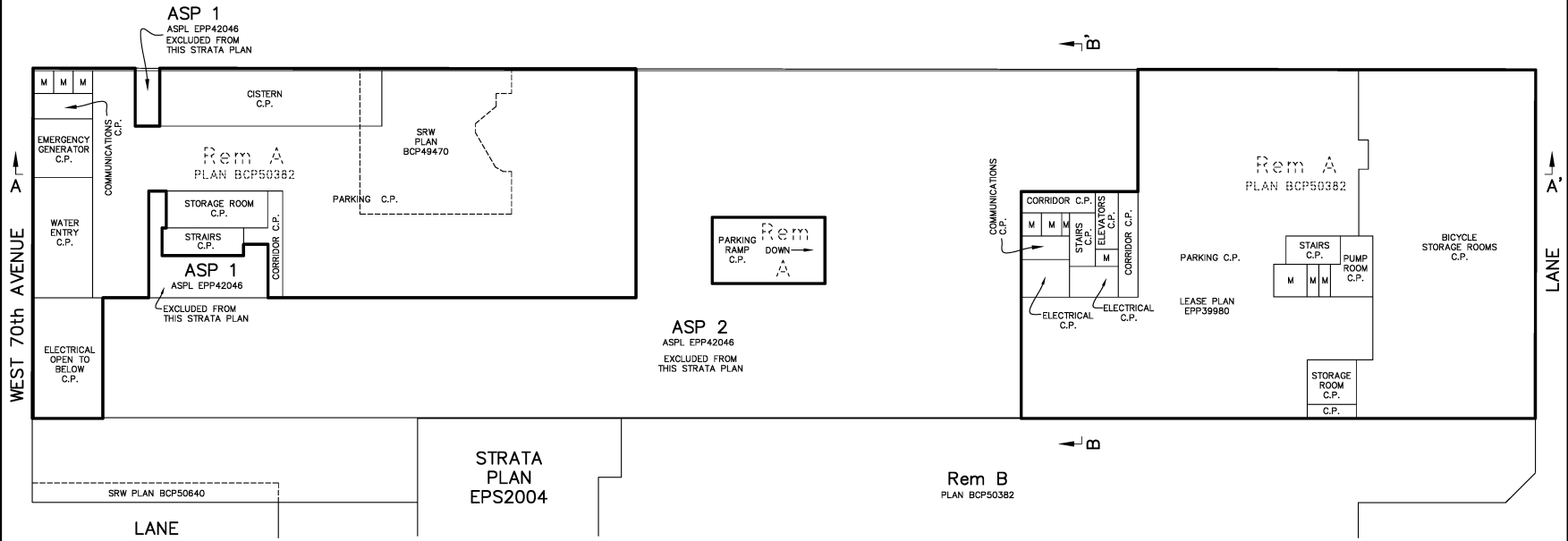
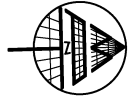

MATSON PECK & TOPLISS
 SURVEYORS & ENGINEERS
 #320 - 11120 HORSESHOE WAY
 RICHMOND, B.C. V7A 5H7
 PH: 604-270-9331 FAX: 604-270-4137
 CADFILE:16400-REM A-STRATA.DWG

HANS J. TROELSEN, BCLS 551
 9th DAY OF SEPTEMBER, 2014

LEVEL 1

SEE SHEET 8 "LEVEL 1 - ENLARGEMENT A" AND SHEET 9 "LEVEL 1 - ENLARGEMENT B" FOR DIMENSIONS



THE INTENDED PLOT SIZE OF THIS PLAN IS 560mm IN WIDTH BY 432mm IN HEIGHT (C SIZE) WHEN PLOTTED AT A SCALE OF 1:300.

THIS SHEET SHOWS WALL DIMENSIONS ACCORDING TO PARAMETERS AS NOTED ON SHEET 1 OF THIS STRATA PLAN.

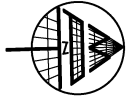

STRATA PLAN EPS2354

CORNISH STREET

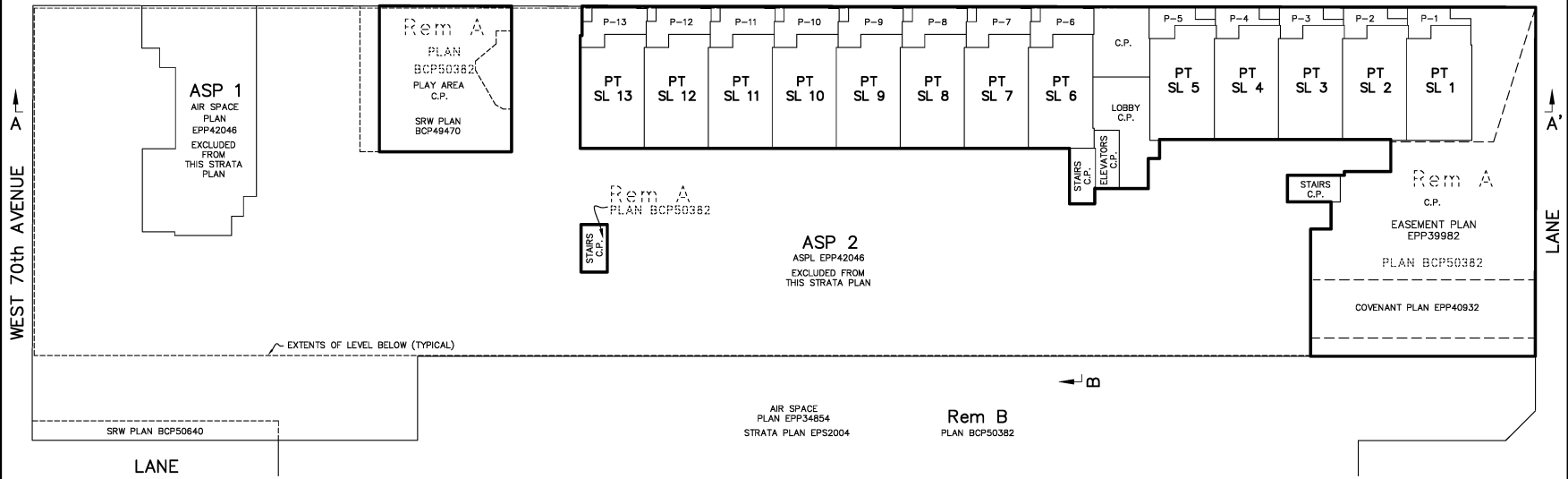

MATSON PECK & TOPLISS
 SURVEYORS & ENGINEERS
 #320 - 11120 HORSESHOE WAY
 RICHMOND, B.C. V7A 5H7
 PH: 604-270-9331 FAX: 604-270-4137
 CADFILE:16400-REM A-STRATA.DWG

HANS J. TROELSEN, BCLS 551
 9th DAY OF SEPTEMBER, 2014

LEVEL 1 - ENLARGEMENT A

SHEET 8 OF 29 SHEETS

STRATA PLAN EPS2354

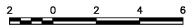

THE INTENDED PLOT SIZE OF THIS PLAN IS
560mm IN WIDTH BY 432mm IN HEIGHT (C SIZE)
WHEN PLOTTED AT A SCALE OF 1:150.

THIS SHEET SHOWS WALL DIMENSIONS ACCORDING TO
PARAMETERS AS NOTED ON SHEET 1 OF THIS STRATA PLAN.

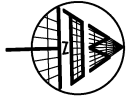

CORNISH STREET

↑ B

MATCH LINE
ENLARGEMENT A
SHEET 8
SHEET 9
ENLARGEMENT B

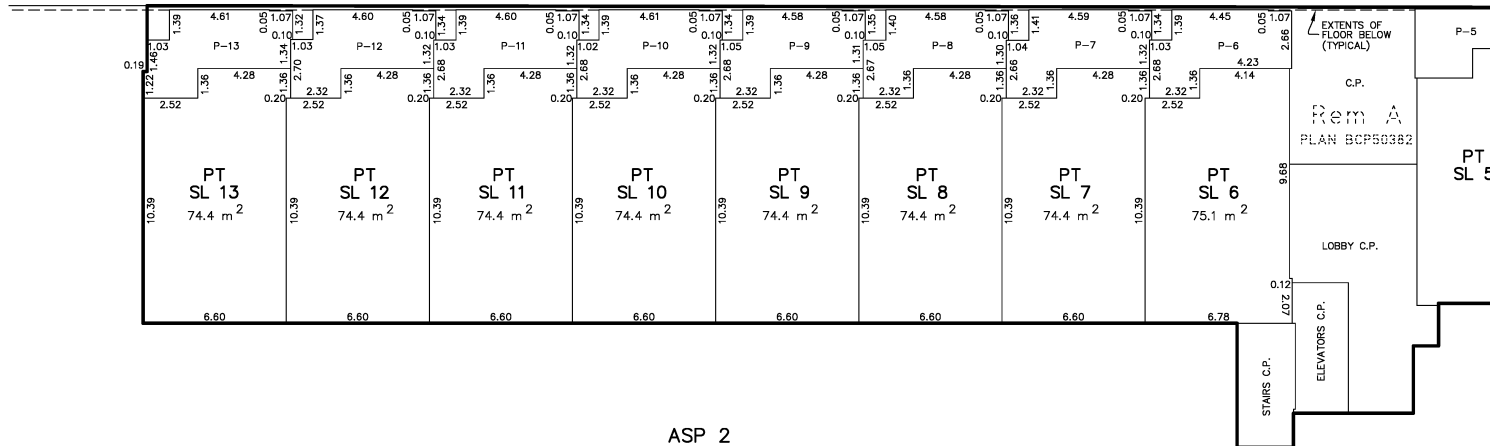

↑ A

↑ A

ASP 2
AIR SPACE PLAN EPP42046
EXCLUDED FROM
THIS STRATA PLAN

↑ B

MATCH LINE
ENLARGEMENT A
SHEET 8
SHEET 9
ENLARGEMENT B

MATSON PECK & TOPLISS
SURVEYORS & ENGINEERS
#320 - 11120 HORSESHOE WAY
RICHMOND, B.C. V7A 5H7
PH: 604-270-9331 FAX: 604-270-4137
CADFILE:16400-REM A-STRATA.DWG

HANS J. TROELSEN, BCLS 551
9th DAY OF SEPTEMBER, 2014

LEVEL 1 - ENLARGEMENT B

SHEET 9 OF 29 SHEETS

STRATA PLAN EPS2354

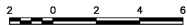

THE INTENDED PLOT SIZE OF THIS PLAN IS 560mm IN WIDTH BY 432mm IN HEIGHT (C SIZE) WHEN PLOTTED AT A SCALE OF 1:150.

THIS SHEET SHOWS WALL DIMENSIONS ACCORDING TO PARAMETERS AS NOTED ON SHEET 1 OF THIS STRATA PLAN.

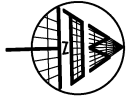

MATCH LINE ENLARGEMENT A SHEET 8
MATCH LINE ENLARGEMENT B SHEET 9

CORNISH STREET

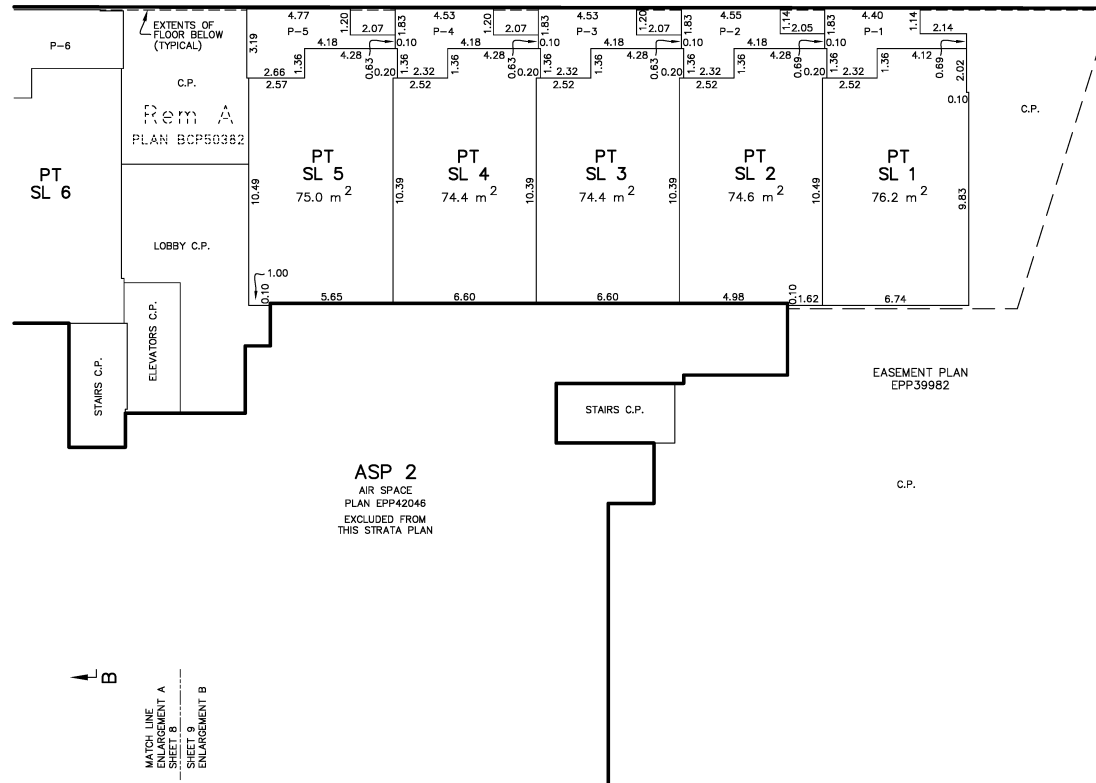

LANE

A

B

MATSON PECK & TOPLISS
SURVEYORS & ENGINEERS
#320 - 11120 HORSESHOE WAY
RICHMOND, B.C. V7A 5H7
PH: 604-270-9331 FAX: 604-270-4137
CADFILE:16400-REM A-STRATA.DWG

HANS J. TROELSEN, BCLS 551
9th DAY OF SEPTEMBER, 2014

LEVEL 3

SEE SHEET 11 "LEVEL 3 - ENLARGEMENT A" AND SHEET 12 "LEVEL 3 - ENLARGEMENT B" FOR DIMENSIONS

"LEVEL 2" AND "LEVEL 4" ARE NOT USED ON THIS PLAN

SHEET 10 OF 29 SHEETS



THE INTENDED PLOT SIZE OF THIS PLAN IS 560mm IN WIDTH BY 432mm IN HEIGHT (C SIZE) WHEN PLOTTED AT A SCALE OF 1:300.

THIS SHEET SHOWS WALL DIMENSIONS ACCORDING TO PARAMETERS AS NOTED ON SHEET 1 OF THIS STRATA PLAN.

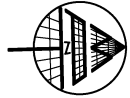

STRATA PLAN EPS2354

CORNISH STREET

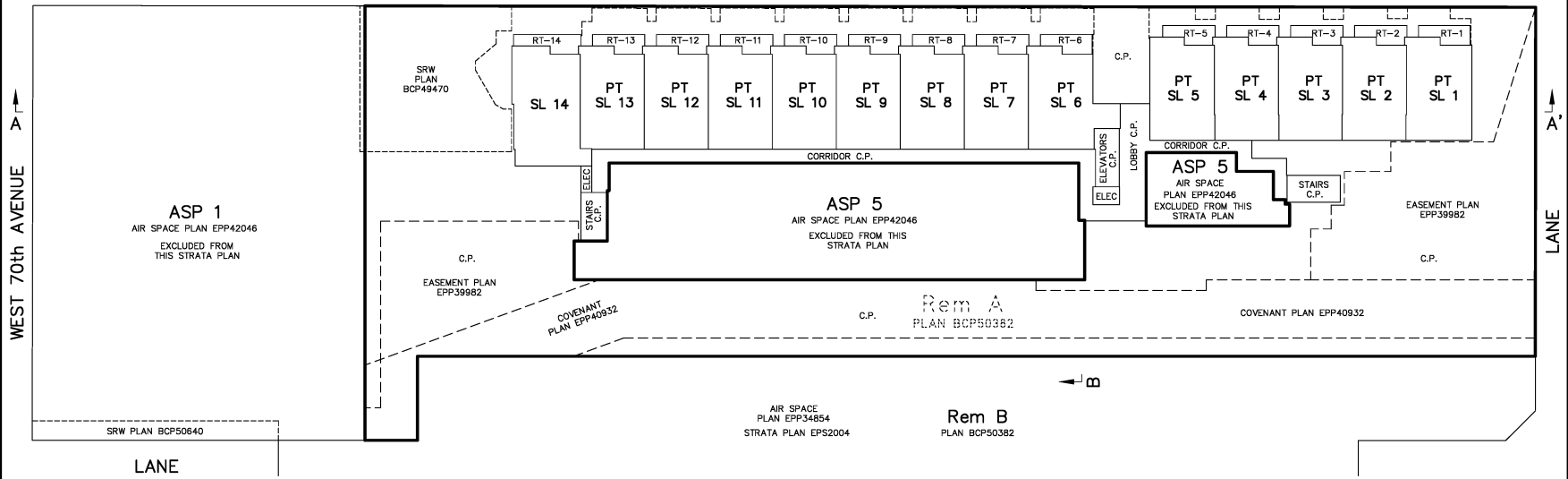

MATSON PECK & TOPLISS
 SURVEYORS & ENGINEERS
 #320 - 11120 HORSESHOE WAY
 RICHMOND, B.C. V7A 5H7
 PH: 604-270-9331 FAX: 604-270-4137
 CADFILE:16400-REM A-STRATA.DWG

HANS J. TROELSEN, BCLS 551
 9th DAY OF SEPTEMBER, 2014

LEVEL 3 – ENLARGEMENT A

LEVEL 2 AND *LEVEL 4* ARE NOT USED ON THIS PLAN

SHEET 11 OF 29 SHEETS

STRATA PLAN EPS2354

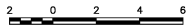

THE INTENDED PLOT SIZE OF THIS PLAN IS 560mm IN WIDTH BY 432mm IN HEIGHT (C SIZE) WHEN PLOTTED AT A SCALE OF 1:150.

THIS SHEET SHOWS WALL DIMENSIONS ACCORDING TO PARAMETERS AS NOTED ON SHEET 1 OF THIS STRATA PLAN.

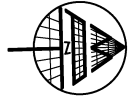

CORNISH STREET

B

MATCH LINE ENLARGEMENT A SHEET 11

MATCH LINE ENLARGEMENT B SHEET 12

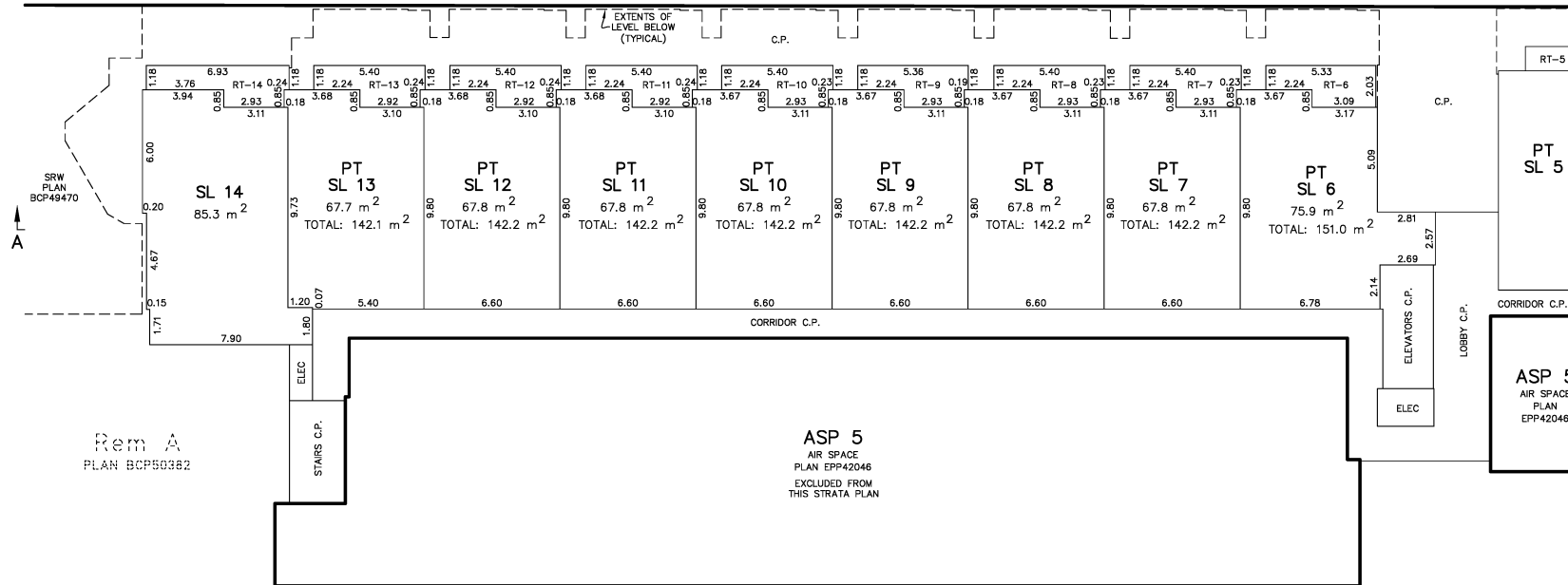

A

A

C.P.

B

MATCH LINE ENLARGEMENT A SHEET 11

MATCH LINE ENLARGEMENT B SHEET 12

MATSON PECK & TOPLISS
 SURVEYORS & ENGINEERS
 #320 - 11120 HORSESHOE WAY
 RICHMOND, B.C. V7A 5H7
 PH: 604.270.9331 FAX: 604.270.4137
 CADFILE:16400-REM A-STRATA.DWG

HANS J. TROELSEN, BCLS 551
 9th DAY OF SEPTEMBER, 2014

LEVEL 3 – ENLARGEMENT B

"LEVEL 2" AND "LEVEL 4" ARE NOT USED ON THIS PLAN

SHEET 12 OF 29 SHEETS

STRATA PLAN EPS2354

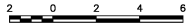

THE INTENDED PLOT SIZE OF THIS PLAN IS 560mm IN WIDTH BY 432mm IN HEIGHT (C SIZE) WHEN PLOTTED AT A SCALE OF 1:150.

THIS SHEET SHOWS WALL DIMENSIONS ACCORDING TO PARAMETERS AS NOTED ON SHEET 1 OF THIS STRATA PLAN.

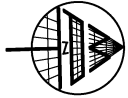

MATCH LINE ENLARGEMENT A SHEET 11
MATCH LINE ENLARGEMENT B SHEET 12

CORNISH STREET

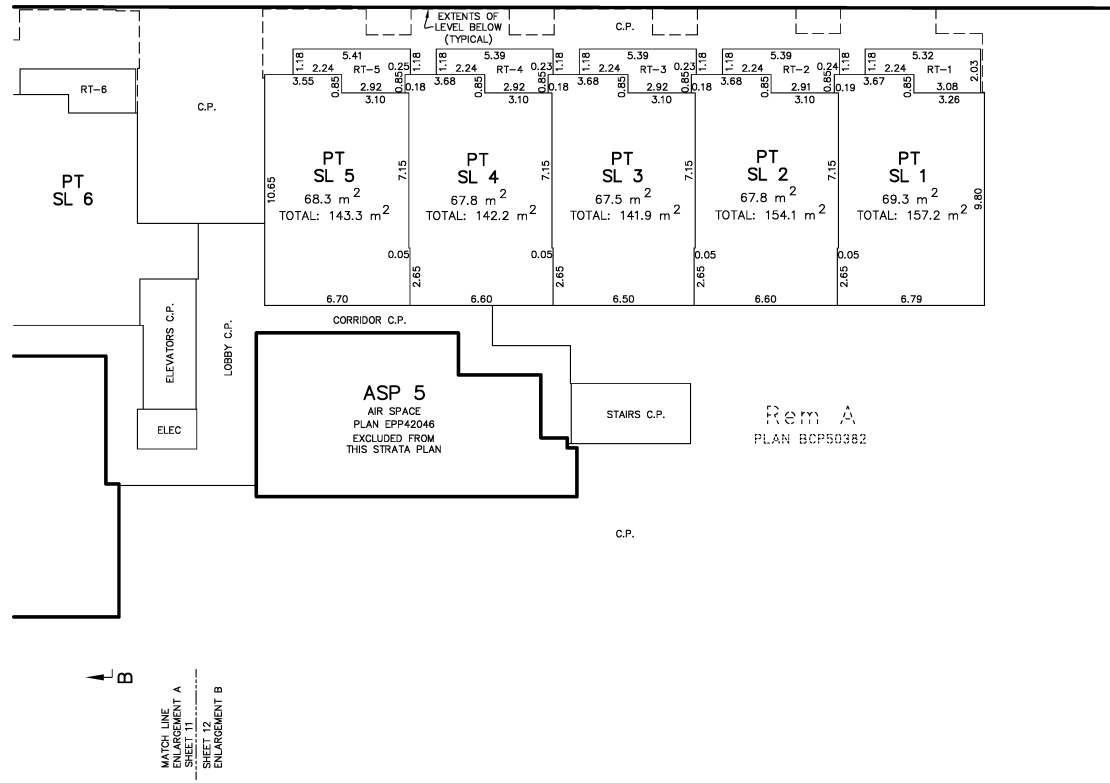

MATSON PECK & TOPLISS
SURVEYORS & ENGINEERS
#320 - 11120 HORSESHOE WAY
RICHMOND, B.C. V7A 5H7
PH: 604-270-9331 FAX: 604-270-4137
CADFILE:16400-REM A-STRATA.DWG

HANS J. TROELSEN, BCLS 551
9th DAY OF SEPTEMBER, 2014

LEVEL 5

SEE SHEET 14 "LEVEL 5 - ENLARGEMENT A" AND SHEET 15 "LEVEL 5 - ENLARGEMENT B" FOR DIMENSIONS

"LEVEL 2" AND "LEVEL 4" ARE NOT USED ON THIS PLAN

SHEET 13 OF 29 SHEETS



THE INTENDED PLOT SIZE OF THIS PLAN IS 560mm IN WIDTH BY 432mm IN HEIGHT (C SIZE) WHEN PLOTTED AT A SCALE OF 1:300.

THIS SHEET SHOWS WALL DIMENSIONS ACCORDING TO PARAMETERS AS NOTED ON SHEET 1 OF THIS STRATA PLAN.

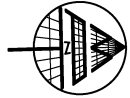

STRATA PLAN EPS2354

CORNISH STREET

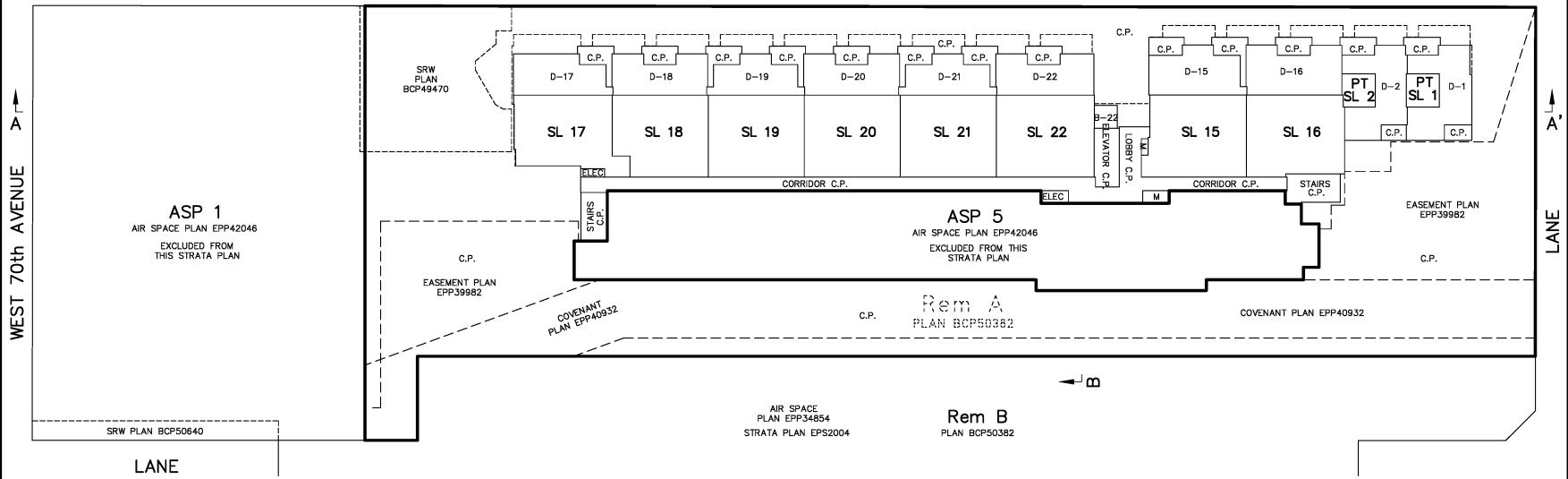

MATSON PECK & TOPLISS
 SURVEYORS & ENGINEERS
 #320 - 11120 HORSESHOE WAY
 RICHMOND, B.C. V7A 5H7
 PH: 604-270-9331 FAX: 604-270-4137
 CADFILE:16400-REM A-STRATA.DWG

HANS J. TROELSEN, BCLS 551
 9th DAY OF SEPTEMBER, 2014

LEVEL 5 - ENLARGEMENT A

"LEVEL 2" AND "LEVEL 4" ARE NOT USED ON THIS PLAN

SHEET 14 OF 29 SHEETS

STRATA PLAN EPS2354

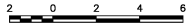

THE INTENDED PLOT SIZE OF THIS PLAN IS 560mm IN WIDTH BY 432mm IN HEIGHT (C SIZE) WHEN PLOTTED AT A SCALE OF 1:150.

THIS SHEET SHOWS WALL DIMENSIONS ACCORDING TO PARAMETERS AS NOTED ON SHEET 1 OF THIS STRATA PLAN.

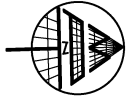

CORNISH STREET

B

MATCH LINE ENLARGEMENT A SHEET 14

MATCH LINE ENLARGEMENT B SHEET 15

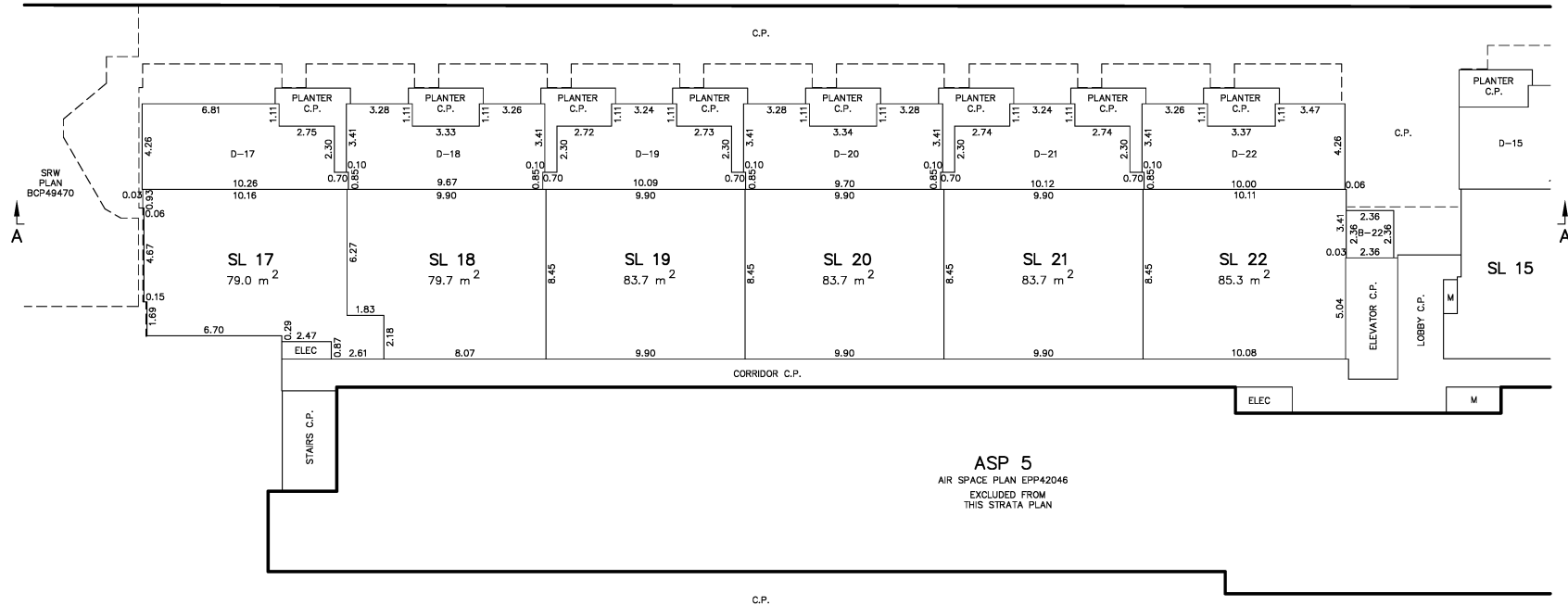

A

A

B

MATCH LINE ENLARGEMENT A SHEET 14

MATCH LINE ENLARGEMENT B SHEET 15

ASP 5
AIR SPACE PLAN EPP42046
EXCLUDED FROM
THIS STRATA PLAN

MATSON PECK & TOPLISS
SURVEYORS & ENGINEERS
#320 - 11120 HORSESHOE WAY
RICHMOND, B.C. V7A 5H7
PH: 604.270.9331 FAX: 604.270.4137
CADFILE:16400-REM A-STRATA.DWG

HANS J. TROELSEN, BCLS 551
9th DAY OF SEPTEMBER, 2014

LEVEL 5 – ENLARGEMENT B

LEVEL 2 AND *LEVEL 4* ARE NOT USED ON THIS PLAN

SHEET 15 OF 29 SHEETS

STRATA PLAN EPS2354

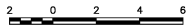

THE INTENDED PLOT SIZE OF THIS PLAN IS 560mm IN WIDTH BY 432mm IN HEIGHT (C SIZE) WHEN PLOTTED AT A SCALE OF 1:150.

THIS SHEET SHOWS WALL DIMENSIONS ACCORDING TO PARAMETERS AS NOTED ON SHEET 1 OF THIS STRATA PLAN.

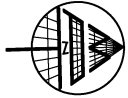

MATCH LINE ENLARGEMENT A SHEET 14
MATCH LINE ENLARGEMENT B SHEET 15

CORNISH STREET

A

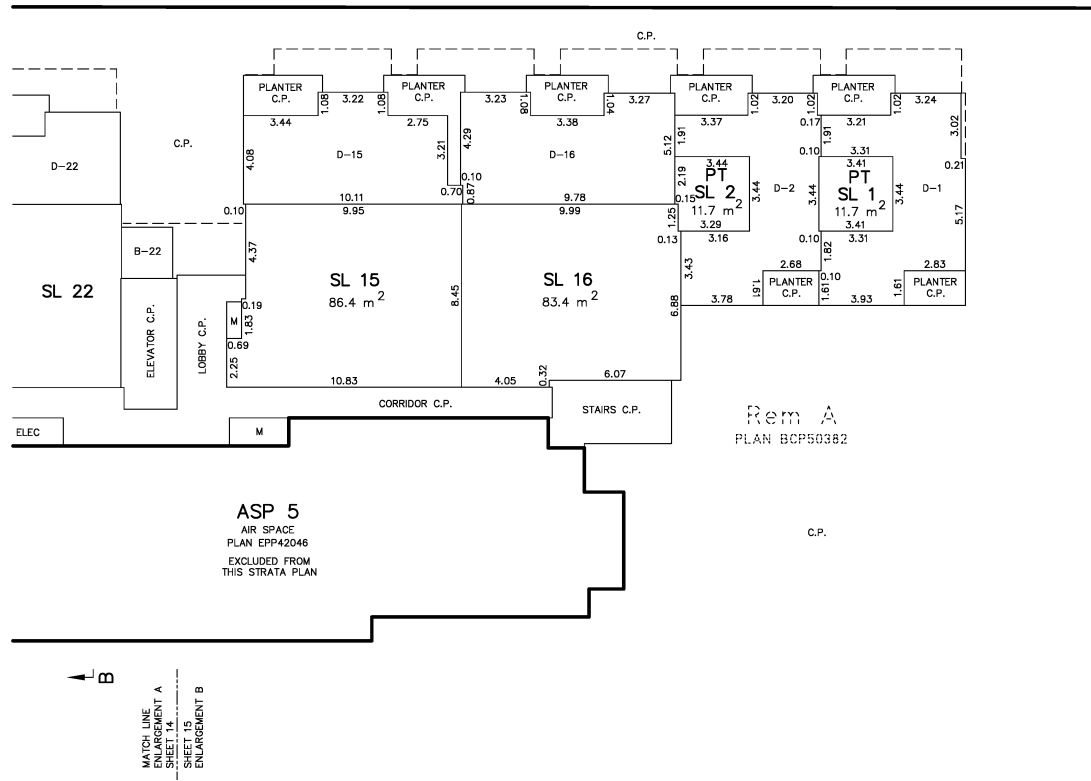

A

MATCH LINE ENLARGEMENT A SHEET 14
MATCH LINE ENLARGEMENT B SHEET 15

MATSON PECK & TOPLISS
SURVEYORS & ENGINEERS
#320 - 11120 HORSESHOE WAY
RICHMOND, B.C. V7A 5H7
PH: 604-270-9331 FAX: 604-270-4137
CADFILE:16400-REM A-STRATA.DWG

HANS J. TROELSEN, BCLS 551
9th DAY OF SEPTEMBER, 2014

LEVEL 6

SEE SHEET 17 "LEVEL 6 - ENLARGEMENT A" AND SHEET 18 "LEVEL 6 - ENLARGEMENT B" FOR DIMENSIONS

SHEET 16 OF 29 SHEETS



THE INTENDED PLOT SIZE OF THIS PLAN IS 560mm IN WIDTH BY 432mm IN HEIGHT (C SIZE) WHEN PLOTTED AT A SCALE OF 1:300.

THIS SHEET SHOWS WALL DIMENSIONS ACCORDING TO PARAMETERS AS NOTED ON SHEET 1 OF THIS STRATA PLAN.

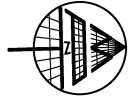

STRATA PLAN EPS2354

CORNISH STREET

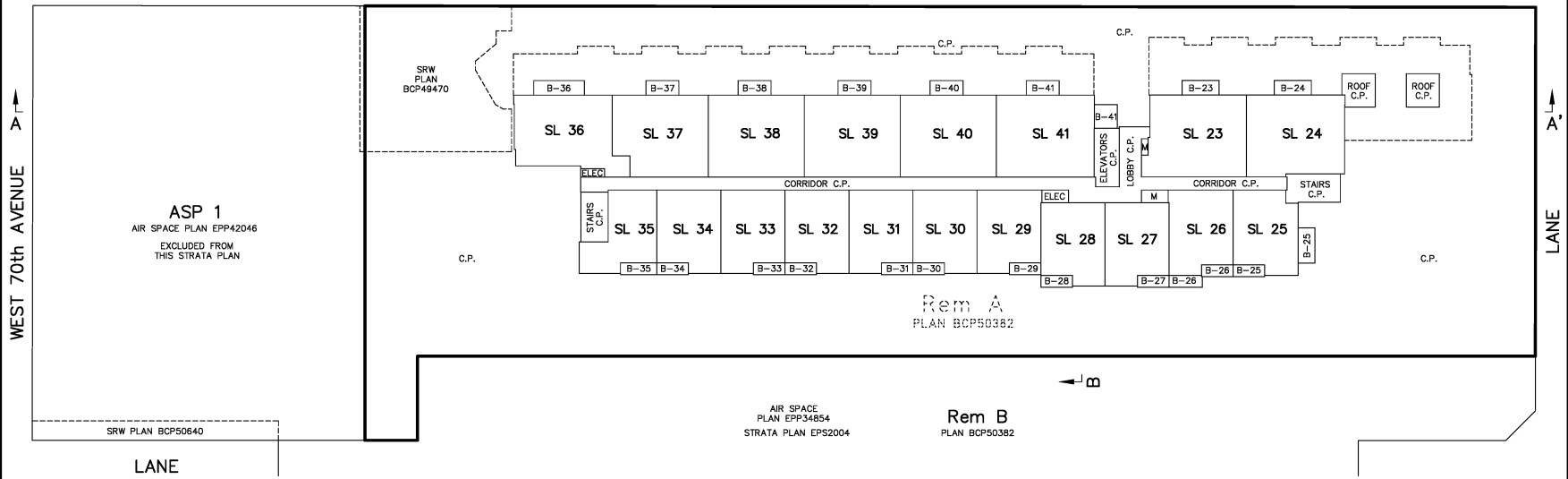

WEST 70th AVENUE

LANE

ASP 1
AIR SPACE PLAN EPP42046
EXCLUDED FROM THIS STRATA PLAN

SRW PLAN BCP50640

AIR SPACE PLAN EPP34854
STRATA PLAN EPS2004

Rem A
PLAN BCP50382

Rem B
PLAN BCP50382

LANE

MATSON PECK & TOPLISS
SURVEYORS & ENGINEERS
#320 - 11120 HORSESHOE WAY
RICHMOND, B.C. V7A 5H7
PH: 604-270-9331 FAX: 604-270-4137
CADFILE:16400-REM A-STRATA.DWG

HANS J. TROELSEN, BCLS 551
9th DAY OF SEPTEMBER, 2014

LEVEL 6 - ENLARGEMENT A

SHEET 17 OF 29 SHEETS

STRATA PLAN EPS2354

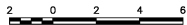

THE INTENDED PLOT SIZE OF THIS PLAN IS 560mm IN WIDTH BY 432mm IN HEIGHT (C SIZE) WHEN PLOTTED AT A SCALE OF 1:150.

THIS SHEET SHOWS WALL DIMENSIONS ACCORDING TO PARAMETERS AS NOTED ON SHEET 1 OF THIS STRATA PLAN.

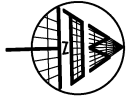

CORNISH STREET

B

MATCH LINE ENLARGEMENT A SHEET 17
SHEET 18 ENLARGEMENT B

SRW PLAN BCP49470
A

A

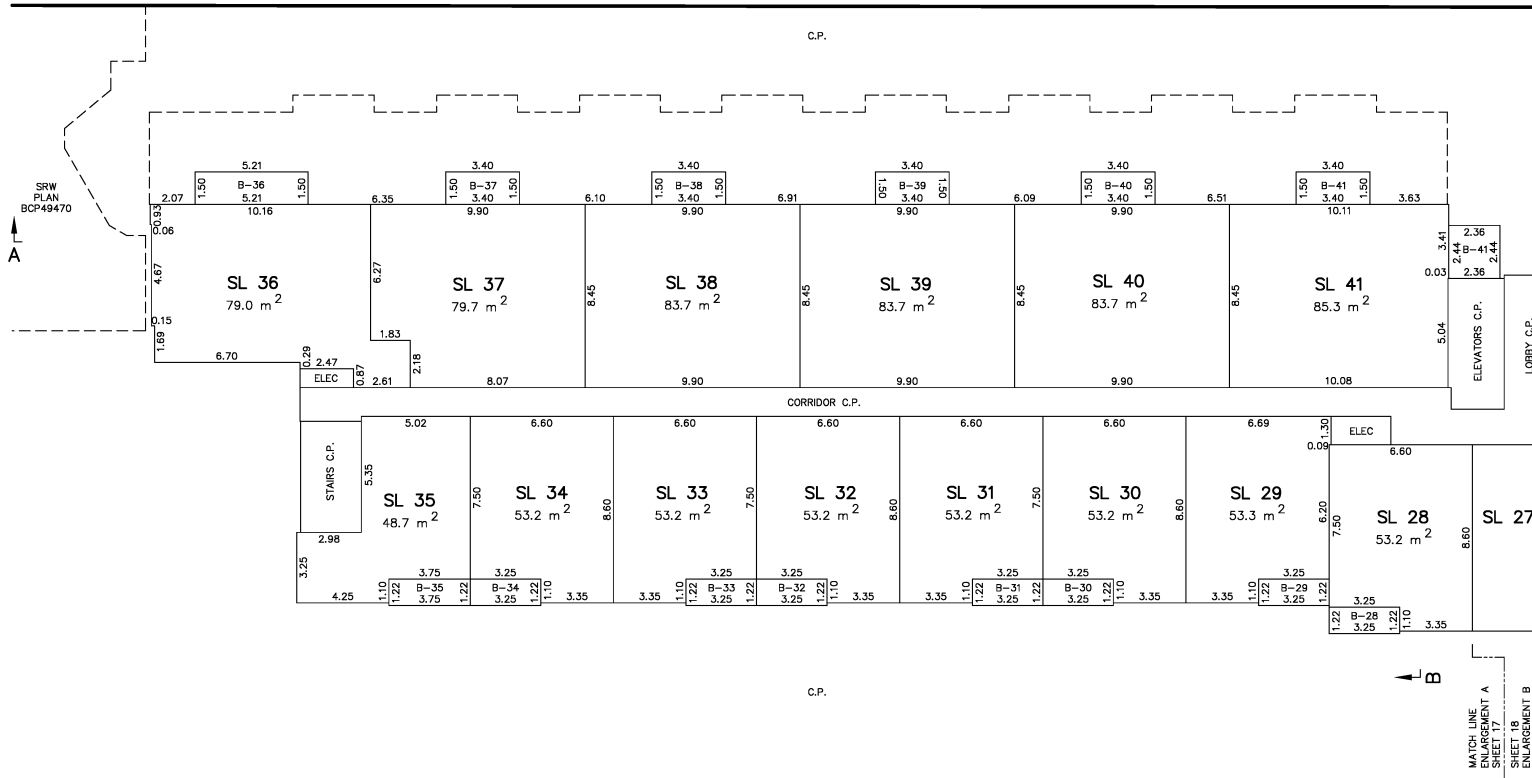

B

MATCH LINE ENLARGEMENT A SHEET 17
SHEET 18 ENLARGEMENT B

MATSON PECK & TOPLISS
 SURVEYORS & ENGINEERS
 #320 - 11120 HORSESHOE WAY
 RICHMOND, B.C. V7A 5H7
 PH: 604-270-9331 FAX: 604-270-4137
 CADFILE:16400-REM A-STRATA.DWG

HANS J. TROELSEN, BCLS 551
 9th DAY OF SEPTEMBER, 2014

LEVEL 6 - ENLARGEMENT B

SHEET 18 OF 29 SHEETS

STRATA PLAN EPS2354

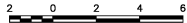

THE INTENDED PLOT SIZE OF THIS PLAN IS
560mm IN WIDTH BY 432mm IN HEIGHT (C SIZE)
WHEN PLOTTED AT A SCALE OF 1:150.

THIS SHEET SHOWS WALL DIMENSIONS ACCORDING TO
PARAMETERS AS NOTED ON SHEET 1 OF THIS STRATA PLAN.

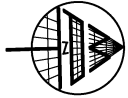

MATCH LINE
ENLARGEMENT A
SHEET 17

MATCH LINE
ENLARGEMENT B
SHEET 18

CORNISH STREET

A

A

LANE

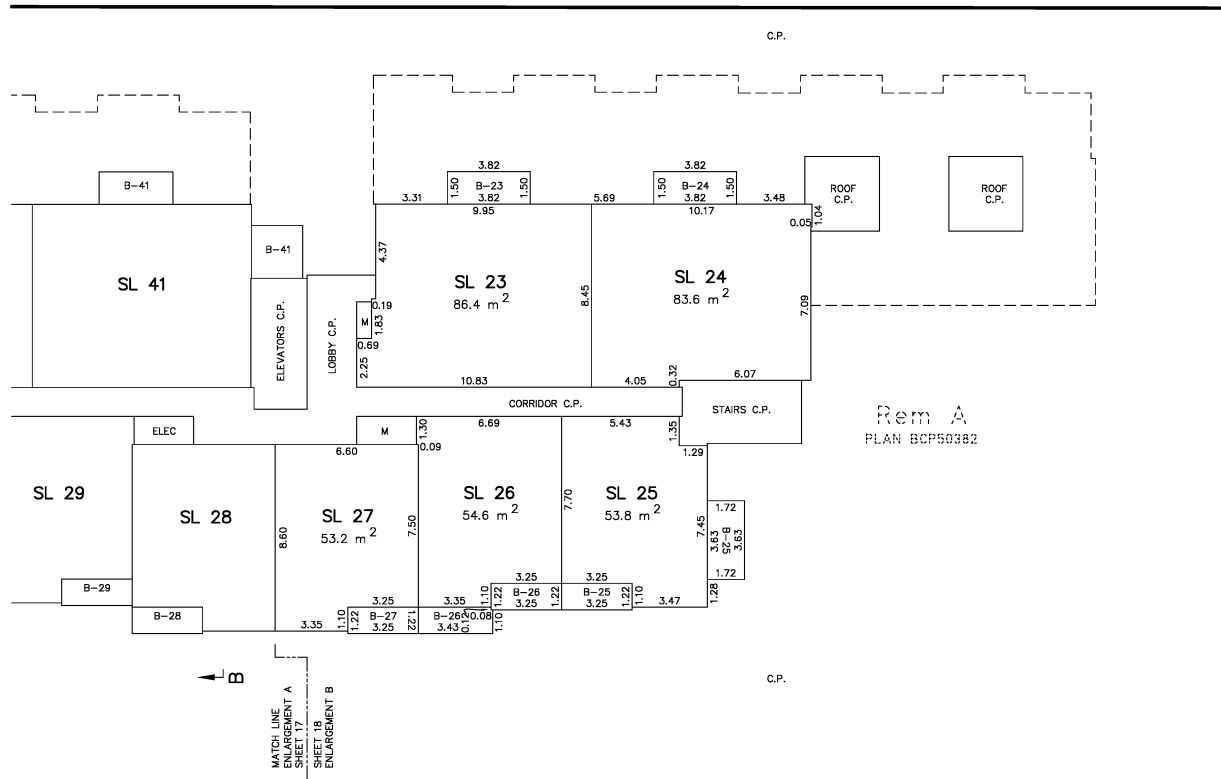

MATSON PECK & TOPLISS
SURVEYORS & ENGINEERS
#320 - 11120 HORSESHOE WAY
RICHMOND, B.C. V7A 5H7
PH: 604-270-9331 FAX: 604-270-4137
CADFILE:16400-REM A-STRATA.DWG

HANS J. TROELSEN, BCLS 551
9th DAY OF SEPTEMBER, 2014

LEVEL 7

SEE SHEET 20 "LEVEL 7 - ENLARGEMENT A" AND SHEET 21 "LEVEL 7 - ENLARGEMENT B" FOR DIMENSIONS

SHEET 19 OF 29 SHEETS



THE INTENDED PLOT SIZE OF THIS PLAN IS 560mm IN WIDTH BY 432mm IN HEIGHT (C SIZE) WHEN PLOTTED AT A SCALE OF 1:300.

THIS SHEET SHOWS WALL DIMENSIONS ACCORDING TO PARAMETERS AS NOTED ON SHEET 1 OF THIS STRATA PLAN.

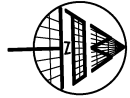

STRATA PLAN EPS2354

CORNISH STREET

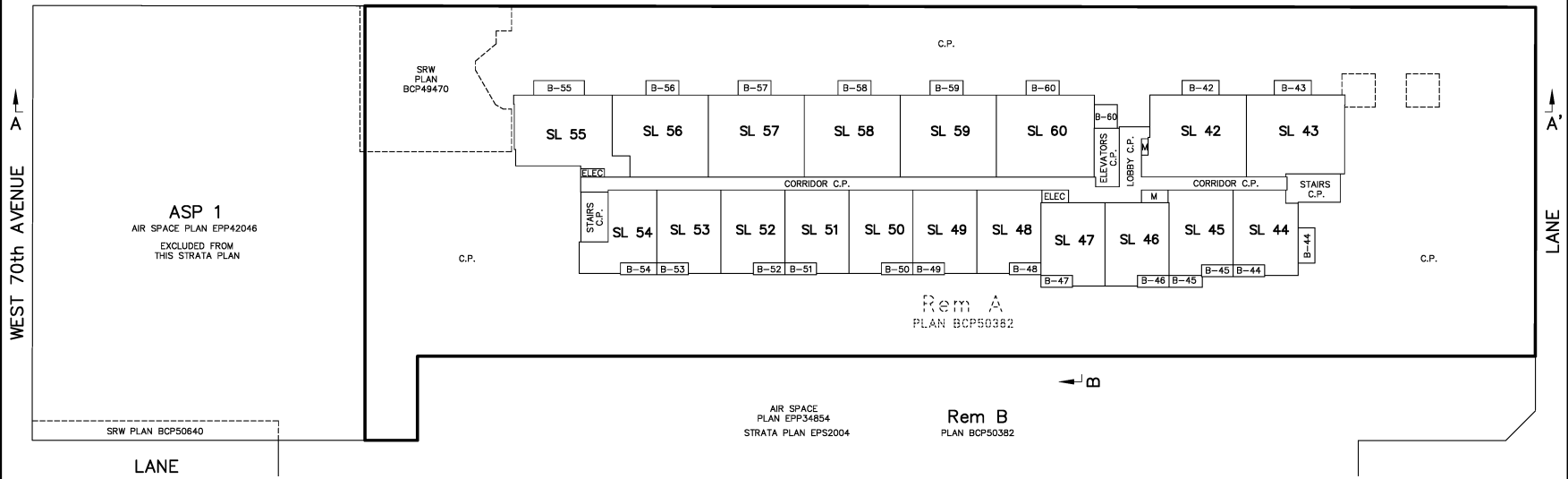

MATSON PECK & TOPLISS
 SURVEYORS & ENGINEERS
 #320 - 11120 HORSESHOE WAY
 RICHMOND, B.C. V7A 5H7
 PH: 604-270-9331 FAX: 604-270-4137
 CADFILE:16400-REM A-STRATA.DWG

HANS J. TROELSEN, BCLS 551
 9th DAY OF SEPTEMBER, 2014

LEVEL 7 - ENLARGEMENT A

SHEET 20 OF 29 SHEETS

STRATA PLAN EPS2354

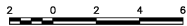

THE INTENDED PLOT SIZE OF THIS PLAN IS 560mm IN WIDTH BY 432mm IN HEIGHT (C SIZE) WHEN PLOTTED AT A SCALE OF 1:150.

THIS SHEET SHOWS WALL DIMENSIONS ACCORDING TO PARAMETERS AS NOTED ON SHEET 1 OF THIS STRATA PLAN.

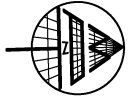

CORNISH STREET

B

MATCH LINE ENLARGEMENT A SHEET 20

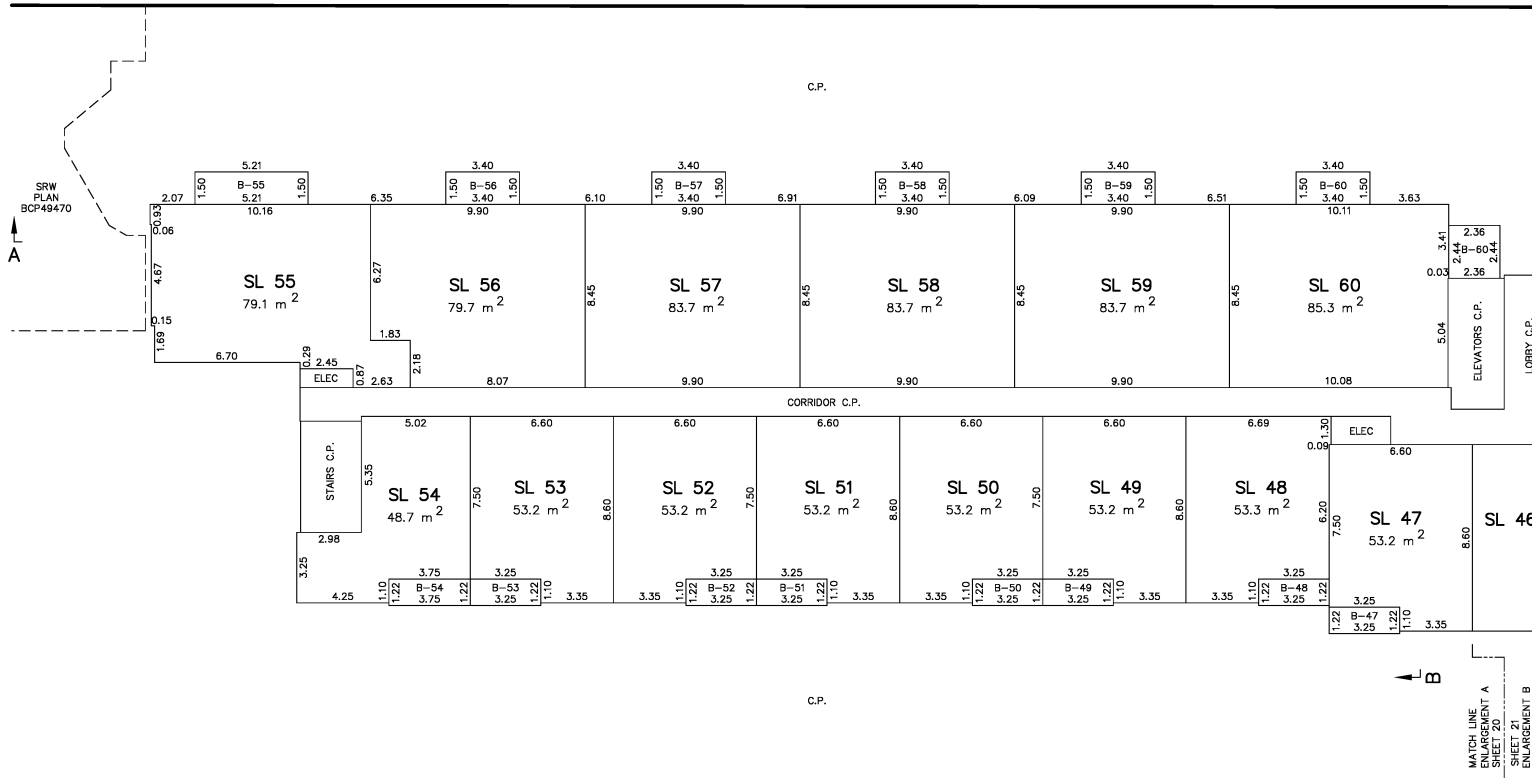

MATSON PECK & TOPLISS
 SURVEYORS & ENGINEERS
 #320 - 11120 HORSESHOE WAY
 RICHMOND, B.C. V7A 5H7
 PH: 604-270-9331 FAX: 604-270-4137
 CADFILE:16400-REM A-STRATA.DWG

HANS J. TROELSEN, BCLS 551
 9th DAY OF SEPTEMBER, 2014

LEVEL 7 - ENLARGEMENT B

SHEET 21 OF 29 SHEETS

STRATA PLAN EPS2354

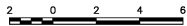

THE INTENDED PLOT SIZE OF THIS PLAN IS
560mm IN WIDTH BY 432mm IN HEIGHT (C SIZE)
WHEN PLOTTED AT A SCALE OF 1:150.

THIS SHEET SHOWS WALL DIMENSIONS ACCORDING TO
PARAMETERS AS NOTED ON SHEET 1 OF THIS STRATA PLAN.

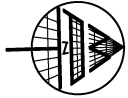

MATCH LINE
 ENLARGEMENT A
 SHEET 20
 SHEET 21
 ENLARGEMENT B

CORNISH STREET

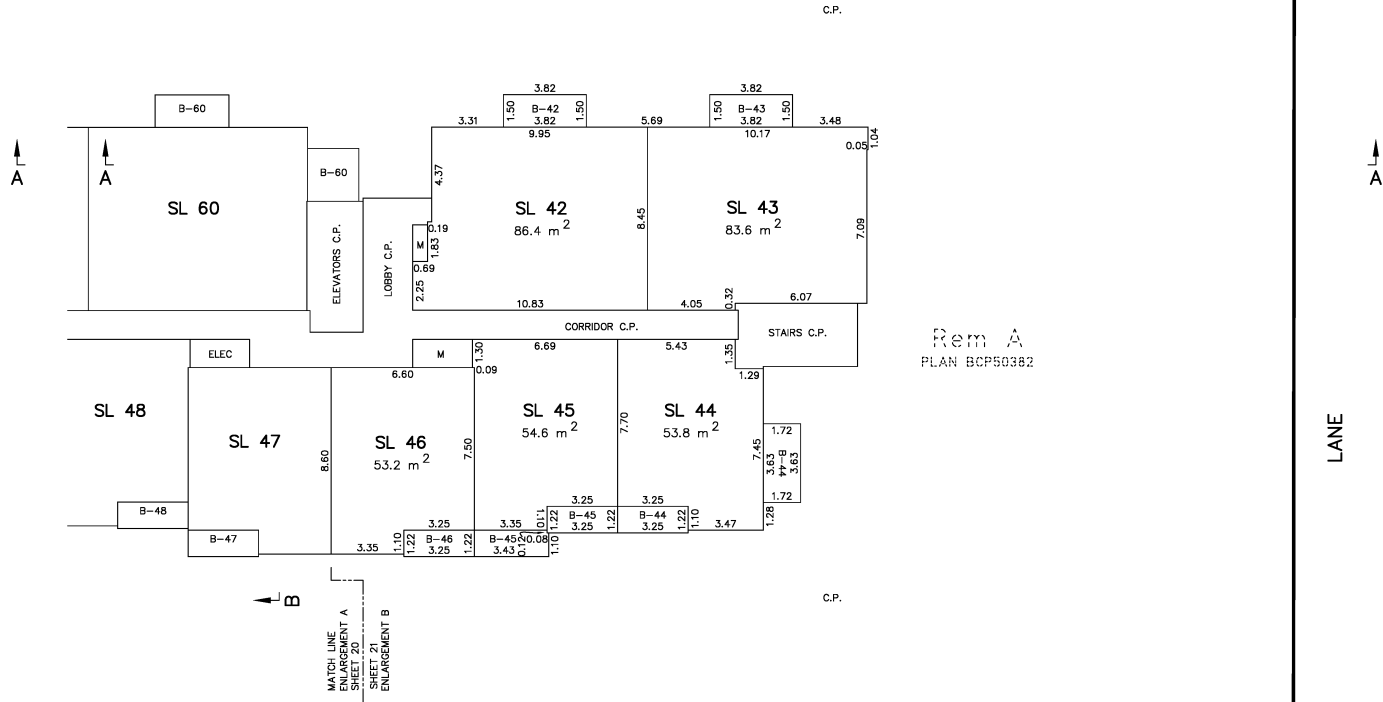

Rem A
PLAN BCP50382

MATSON PECK & TOPLISS
 SURVEYORS & ENGINEERS
 #320 - 11120 HORSESHOE WAY
 RICHMOND, B.C. V7A 5H7
 PH: 604-270-9331 FAX: 604-270-4137
 CADFILE:16400-REM A-STRATA.DWG

HANS J. TROELSEN, BCLS 551
 9th DAY OF SEPTEMBER, 2014

LEVEL 8

SEE SHEET 23 "LEVEL 8 - ENLARGEMENT A" AND SHEET 24 "LEVEL 8 - ENLARGEMENT B" FOR DIMENSIONS

SHEET 22 OF 29 SHEETS



THE INTENDED PLOT SIZE OF THIS PLAN IS 560mm IN WIDTH BY 432mm IN HEIGHT (C SIZE) WHEN PLOTTED AT A SCALE OF 1:300.

THIS SHEET SHOWS WALL DIMENSIONS ACCORDING TO PARAMETERS AS NOTED ON SHEET 1 OF THIS STRATA PLAN.

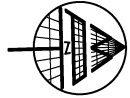

STRATA PLAN EPS2354

CORNISH STREET

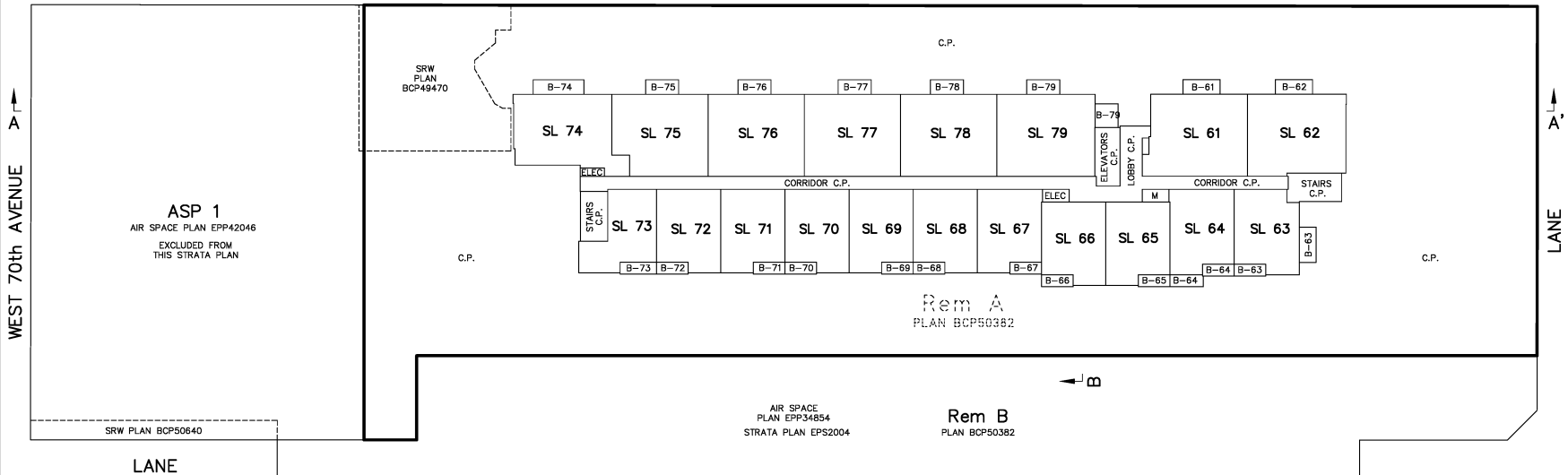

MATSON PECK & TOPLISS
 SURVEYORS & ENGINEERS
 #320 - 11120 HORSESHOE WAY
 RICHMOND, B.C. V7A 5H7
 PH: 604-270-9331 FAX: 604-270-4137
 CADFILE:16400-REM A-STRATA.DWG

HANS J. TROELSEN, BCLS 551
 9th DAY OF SEPTEMBER, 2014

LEVEL 8 - ENLARGEMENT A

SHEET 23 OF 29 SHEETS

STRATA PLAN EPS2354

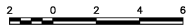

THE INTENDED PLOT SIZE OF THIS PLAN IS 560mm IN WIDTH BY 432mm IN HEIGHT (C SIZE) WHEN PLOTTED AT A SCALE OF 1:150.

THIS SHEET SHOWS WALL DIMENSIONS ACCORDING TO PARAMETERS AS NOTED ON SHEET 1 OF THIS STRATA PLAN.

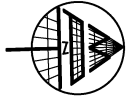

CORNISH STREET

MATCH LINE ENLARGEMENT A SHEET 23

MATCH LINE ENLARGEMENT B SHEET 24

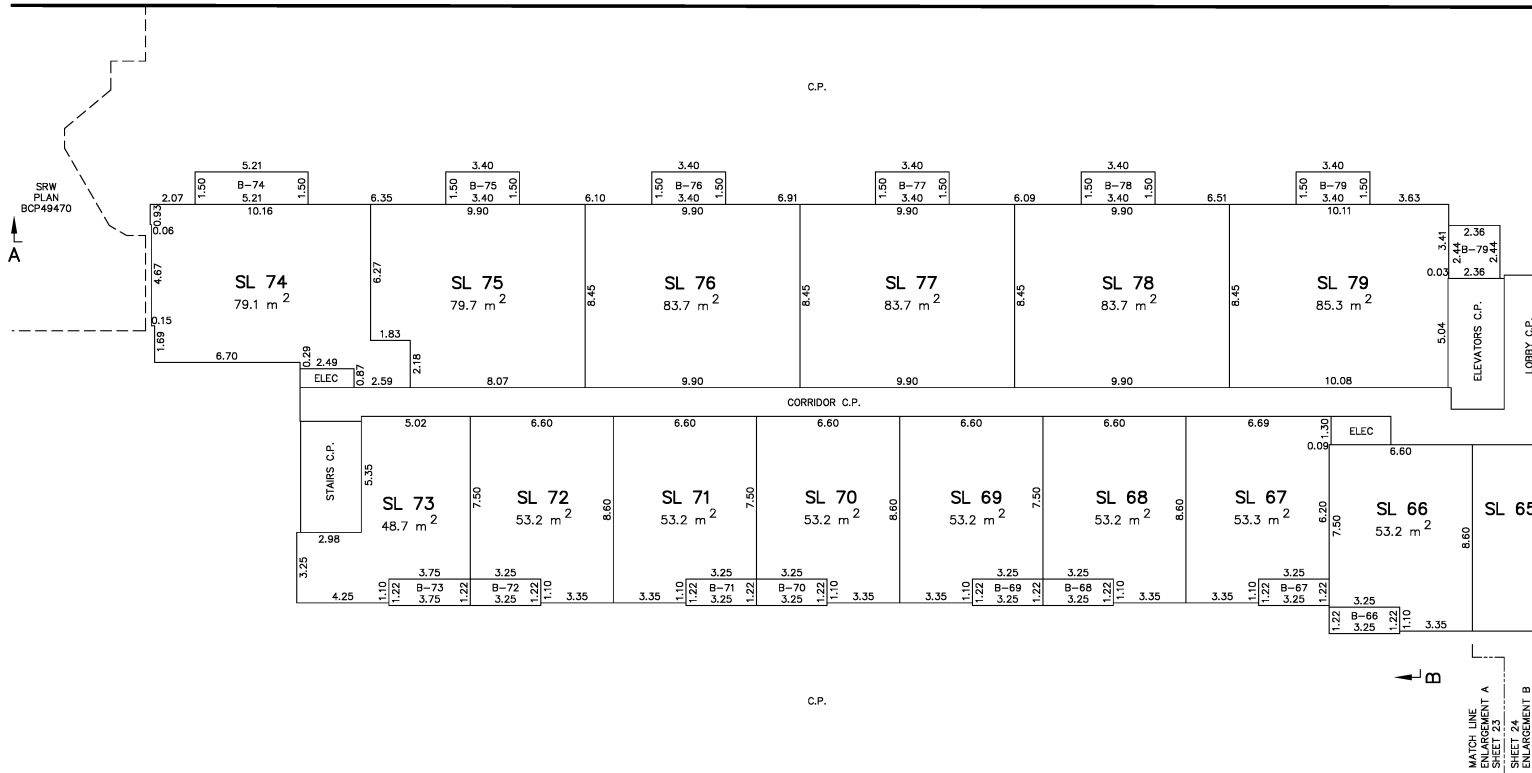

MATSON PECK & TOPLISS
 SURVEYORS & ENGINEERS
 #320 - 11120 HORSESHOE WAY
 RICHMOND, B.C. V7A 5H7
 PH: 604-270-9331 FAX: 604-270-4137
 CADFILE:16400-REM A-STRATA.DWG

HANS J. TROELSEN, BCLS 551
 9th DAY OF SEPTEMBER, 2014

LEVEL 8 - ENLARGEMENT B

SHEET 24 OF 29 SHEETS

STRATA PLAN EPS2354

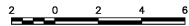

THE INTENDED PLOT SIZE OF THIS PLAN IS
560mm IN WIDTH BY 432mm IN HEIGHT (C SIZE)
WHEN PLOTTED AT A SCALE OF 1:150.

THIS SHEET SHOWS WALL DIMENSIONS ACCORDING TO
PARAMETERS AS NOTED ON SHEET 1 OF THIS STRATA PLAN.

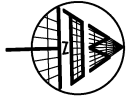

MATCH LINE
ENLARGEMENT A
SHEET 23

MATCH LINE
ENLARGEMENT B
SHEET 24

CORNISH STREET

A

A

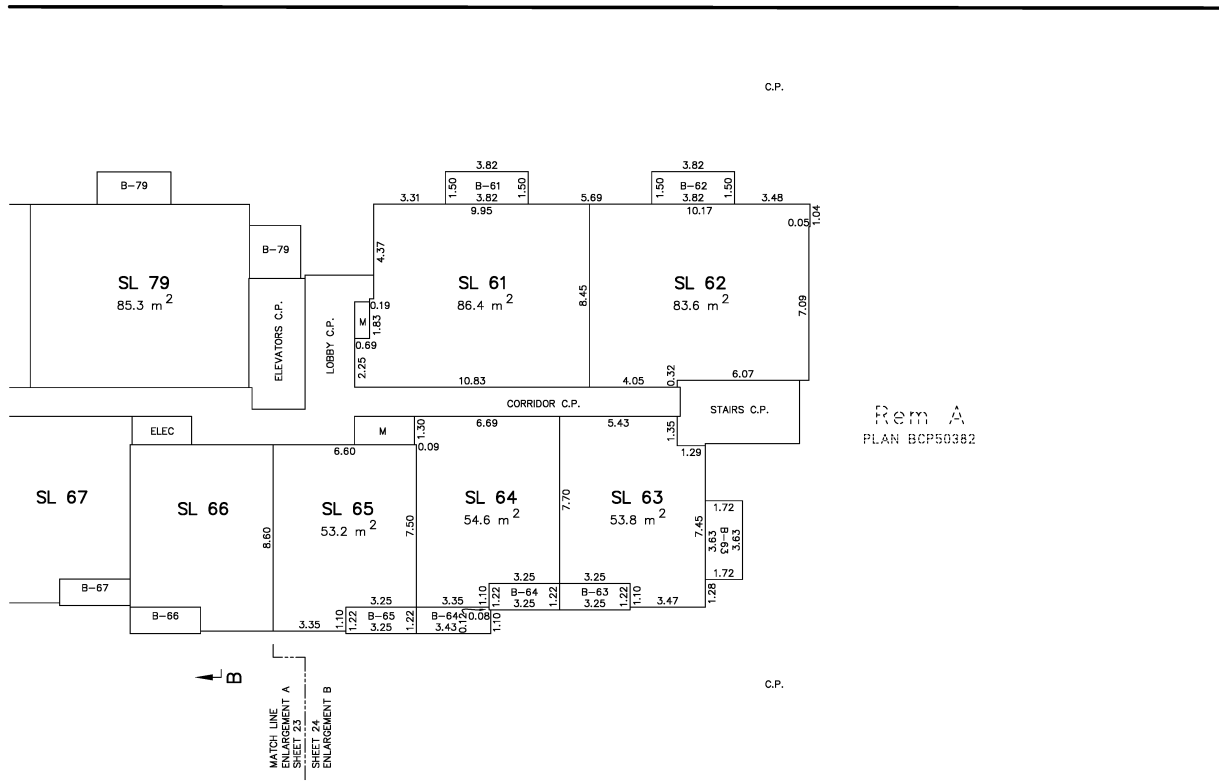

MATSON PECK & TOPLISS
SURVEYORS & ENGINEERS
#320 - 11120 HORSESHOE WAY
RICHMOND, B.C. V7A 5H7
PH: 604-270-9331 FAX: 604-270-4137
CADFILE:16400-REM A-STRATA.DWG

HANS J. TROELSEN, BCLS 551
9th DAY OF SEPTEMBER, 2014

LEVEL 9 SEE SHEET 26 "LEVEL 9 - ENLARGEMENT" FOR DIMENSIONS

SHEET 25 OF 29 SHEETS

STRATA PLAN EPS2354

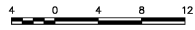

THE INTENDED PLOT SIZE OF THIS PLAN IS 560mm IN WIDTH BY 432mm IN HEIGHT (C SIZE) WHEN PLOTTED AT A SCALE OF 1:300.

THIS SHEET SHOWS WALL DIMENSIONS ACCORDING TO PARAMETERS AS NOTED ON SHEET 1 OF THIS STRATA PLAN.

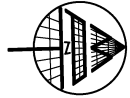

CORNISH STREET

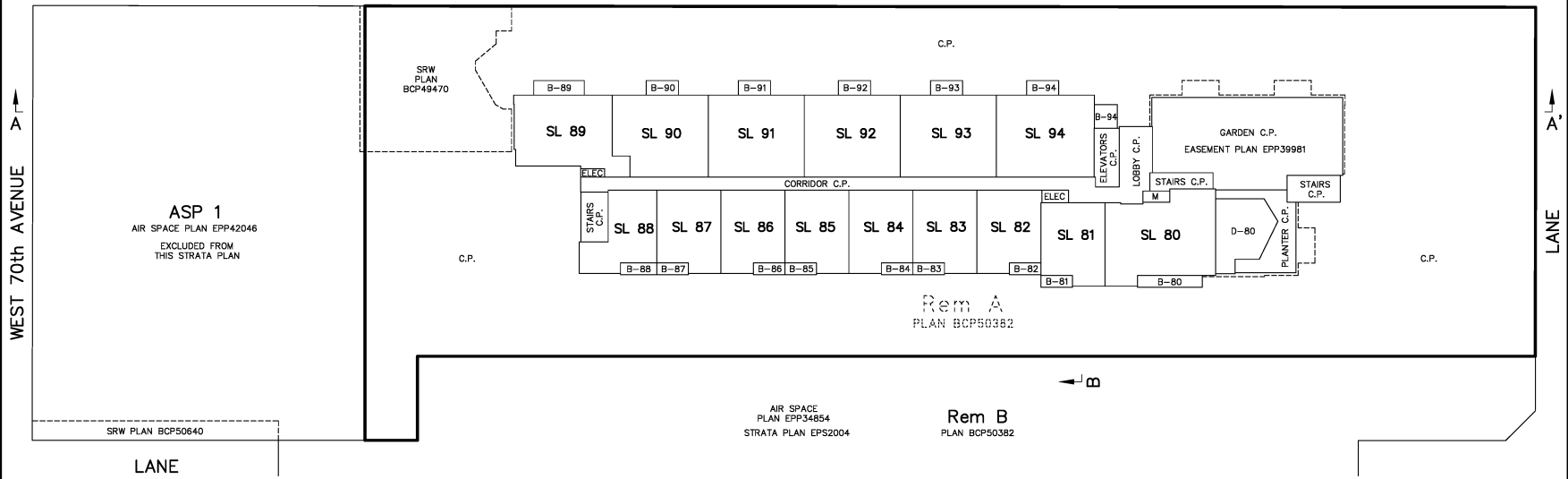

MATSON PECK & TOPLISS
 SURVEYORS & ENGINEERS
 #320 - 11120 HORSESHOE WAY
 RICHMOND, B.C. V7A 5H7
 PH: 604-270-9331 FAX: 604-270-4137
 CADFILE:16400-REM A-STRATA.DWG

HANS J. TROELSEN, BCLS 551
 9th DAY OF SEPTEMBER, 2014

LEVEL 9 - ENLARGEMENT

SHEET 26 OF 29 SHEETS

STRATA PLAN EPS2354



THE INTENDED PLOT SIZE OF THIS PLAN IS
560mm IN WIDTH BY 432mm IN HEIGHT (C SIZE)
WHEN PLOTTED AT A SCALE OF 1:150.

THIS SHEET SHOWS WALL DIMENSIONS ACCORDING TO
PARAMETERS AS NOTED ON SHEET 1 OF THIS STRATA PLAN.

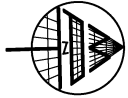

CORNISH STREET

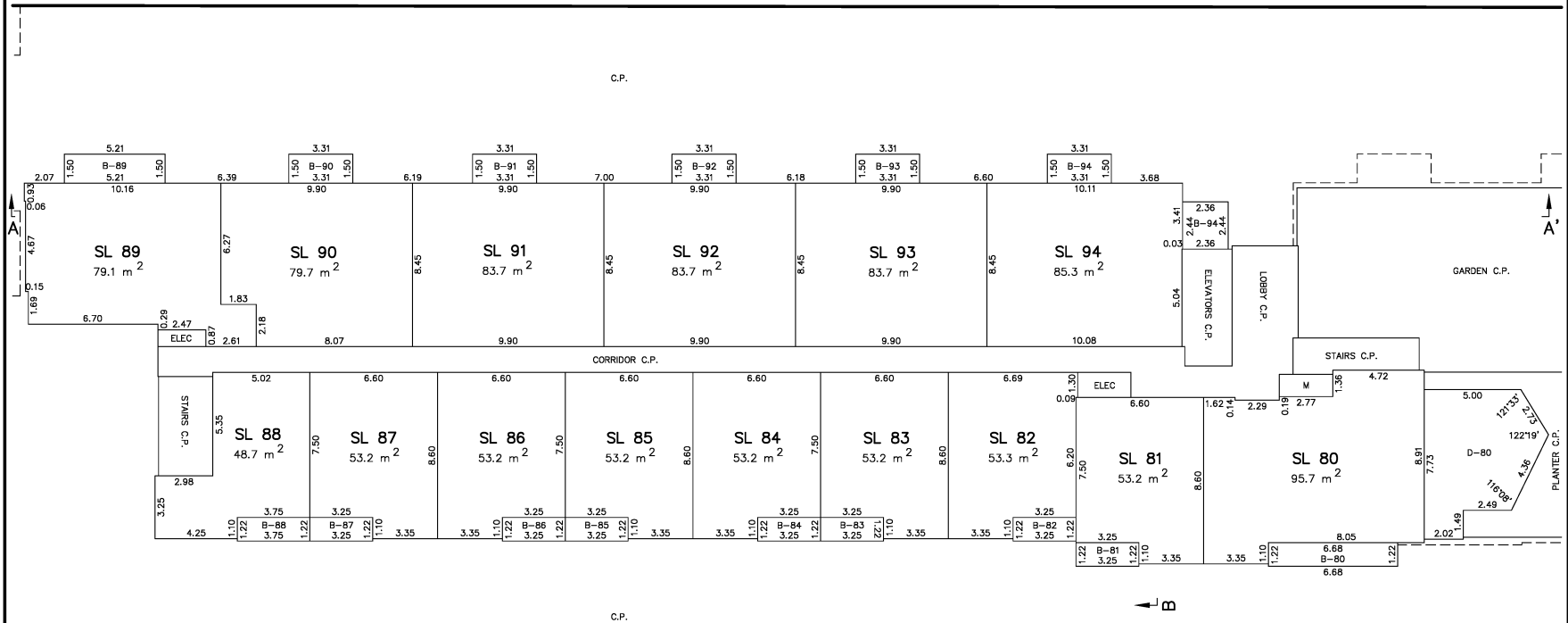

MATSON PECK & TOPLISS
SURVEYORS & ENGINEERS
#320 - 11120 HORSESHOE WAY
RICHMOND, B.C. V7A 5H7
PH: 604.270.9331 FAX: 604.270.4137
CADFILE:16400-REM A-STRATA.DWG

HANS J. TROELSEN, BCLS 551
9th DAY OF SEPTEMBER, 2014

ROOF



THE INTENDED PLOT SIZE OF THIS PLAN IS
560mm IN WIDTH BY 432mm IN HEIGHT (C SIZE)
WHEN PLOTTED AT A SCALE OF 1:300.

THIS SHEET SHOWS WALL DIMENSIONS ACCORDING TO
PARAMETERS AS NOTED ON SHEET 1 OF THIS STRATA PLAN.

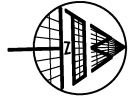

STRATA PLAN EPS2354

CORNISH STREET

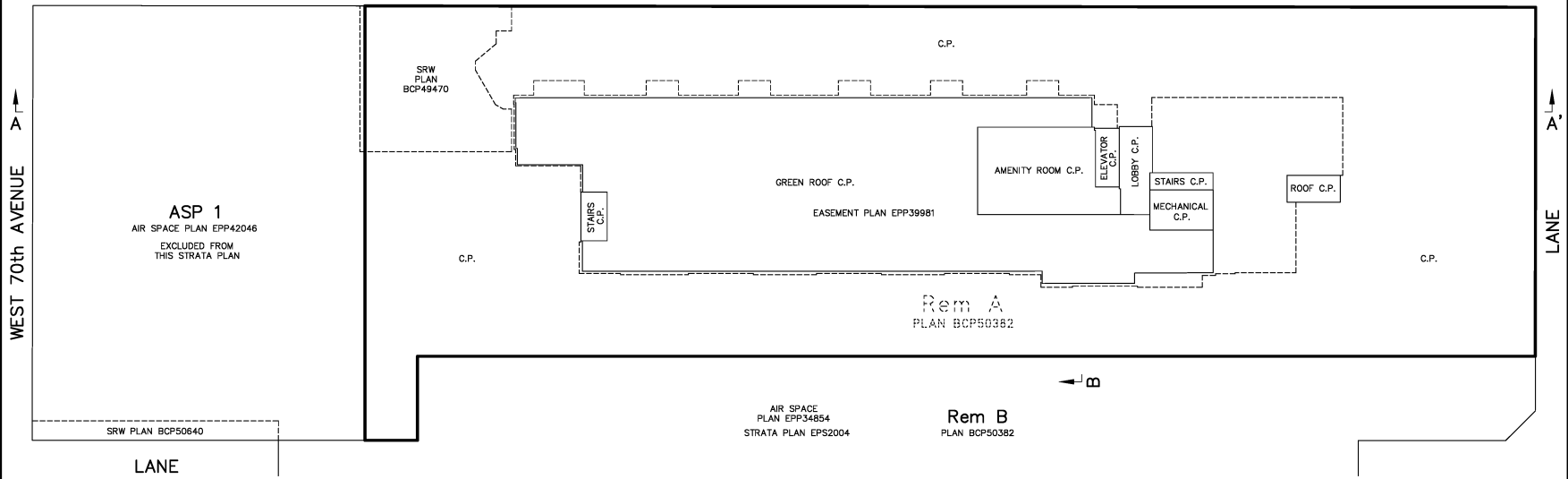

MATSON PECK & TOPLISS
SURVEYORS & ENGINEERS
#320 - 11120 HORSESHOE WAY
RICHMOND, B.C. V7A 5H7
PH: 604-270-9331 FAX: 604-270-4137
CADFILE:16400-REM A-STRATA.DWG

HANS J. TROEISEN, BCLS 551
9th DAY OF SEPTEMBER, 2014

SECTION A-A'



THE INTENDED PLOT SIZE OF THIS PLAN IS 560mm IN WIDTH BY 432mm IN HEIGHT (C SIZE) WHEN PLOTTED AT A SCALE OF 1:300.

SHEET 28 OF 29 SHEETS

STRATA PLAN EPS2354

Rem A
PLAN BCP50382

C.P.

WEST 70th AVENUE

LANE

ASP 1
EXCLUDED FROM THIS STRATA PLAN

ASP 2 AIR SPACE PLAN EPP42046 ASP 2 EXCLUDED FROM THIS STRATA PLAN

PLAY AREA C.P. LEVEL 1

EASEMENT PLAN EPP39981															EASEMENT PLAN EPP39981				
GREEN ROOF C.P.															GARDEN C.P.				
ROOF																			
LEVEL 9	SL 89	SL 90	SL 91	SL 92	SL 93	SL 94	B-94	SL 61	SL 62										
LEVEL 8	SL 74	SL 75	SL 76	SL 77	SL 78	SL 79	B-78	SL 42	SL 43										
LEVEL 7	SL 55	SL 56	SL 57	SL 58	SL 59	SL 60	B-60	SL 23	SL 24										
LEVEL 6	SL 36	SL 37	SL 38	SL 39	SL 40	SL 41	B-41	SL 15	SL 16	D-2	D-1								
LEVEL 5	SL 17	SL 18	SL 19	SL 20	SL 21	SL 22	B-22	LOBBY C.P.	PT SL 5	PT SL 4	PT SL 3	PT SL 2	PT SL 1	C.P.					
LEVEL 4	SL 14	PT SL 13	PT SL 12	PT SL 11	PT SL 10	PT SL 9	PT SL 8	PT SL 7	PT SL 6	LOBBY C.P.	PT SL 5	PT SL 4	PT SL 3	PT SL 2	PT SL 1	C.P.			

EMERGENCY GENERATOR C.P.	PARKING LEVEL P1		PARKING C.P.	ASP 2 EXCLUDED FROM THIS STRATA PLAN ASP1 EPP42046										PARKING C.P.	LEASE PLAN EPP39980	PARKING LEVEL P1		LEASE PLAN EPP39980	BICYCLE STORAGE ROOMS C.P.
PARKING LEVEL P2		LEASE PLAN EPP39979										PARKING LEVEL P2							
PARKING LEVEL P3		LEASE PLAN EPP39978										PARKING LEVEL P3							

C.P.

MATSON PECK & TOPLISS
SURVEYORS & ENGINEERS
#320 - 11120 HORSESHOE WAY
RICHMOND, B.C. V7A 5H7
PH: 604-270-9331 FAX: 604-270-4137
CADFILE:16400-REM A-STRATA.DWG

HANS J. TROELSEN, BCLS 551
9th DAY OF SEPTEMBER, 2014

